

KEB





COMBIVERT F5

INSTRUCTIONS FOR USE | INSTALLATION F5 HOUSING A

Translation of the original manual
Document 20119823 EN 1L

This manual describes the KEB COMBIVERT F5. Particular attention is paid to the installation, the connection as well as the basic operation. Due to the various application and programming possibilities, the application-specific connection and/or wiring diagram, the parameter adjustment as well as instructions to the start-up are to be taken from the documentation of the machine manufacturer.

A list of instruction manuals and documents giving assistance for the construction, documentation and service is provided at the end of this manual. The safety and warning notes listed in this instruction manual as well as in other documentation must be observed at any rate to ensure a safe operation. Non-observance of the safety instructions leads to the loss of any liability claims. The safety and warning instructions specified in this manual do not lay claim on completeness. KEB reserves the right to change/adapt specifications and technical data without prior notice. The used pictograms have following significance:

	Danger Warning Caution	Is used, if life or health of the user are endangered or substantial damage to property can occur.
	Attention observe at all costs	Is used, if a measure is necessary for safe and trouble-free operation.
	Information Aide Tip	Is used, if a measure simplifies the handling or operation of the unit.

The information contained in the technical documentation, as well as any user-specific advice in spoken and written and through tests, are made to best of our knowledge and information about the application. However, they are considered for information only without responsibility. This also applies to any violation of industrial property rights of a third-party.

Inspection of our units in view of their suitability for the intended use must be done generally by the user. Inspections are particularly necessary, if changes are executed, which serve for the further development or adaption of our products to the applications (hardware, software or download lists). Inspections must be repeated completely, even if only parts of hardware, software or download lists are modified. Original spare parts and authorized accessories by the manufacturer serve as security. The use of other parts excludes liability for the damages which can result from it. Application and use of our units in the target products is outside of our control and therefore exclusively in the area of responsibility of the user. Repairs may only be carried out by the manufacturer or an authorised repair agency. Unauthorised opening and tampering may lead to bodily injury and property damage and may entail the loss of warranty rights.

1.	Safety and operating instructions	4
2.	Product description.....	5
2.1	Intended use	5
2.2	Unit identification	5
2.3	Technical Data of the 230 V Class	6
2.4	Technical Data of the 400 V Class	7
2.5	Dimensions and Terminals.....	8
3.	Installation and Connection	9
3.1	Control cabinet installation	9
3.2	EMC-conform Installation.....	9
3.3	Connection of Power Circuit.....	10
3.3.1	Wiring instructions.....	10
3.3.2	Mains connection terminal strip X1A.....	10
3.3.3	Terminal strip X1B	11
3.3.4	Motor connection.....	11
3.3.5	Connection of the temperature monitoring.....	11
3.3.6	Connection of a braking resistor with temperature monitoring in accordance with UL.....	12
3.4	Control Board Basic.....	13
3.4.1	X2A Control terminal strip.....	13
3.4.2	Connection of the control terminal strip.....	14
4.	Operation of the Unit.....	15
4.1	Operation Accessories	15
4.1.1	With HSP5 cable and without operator	15
4.1.2	Digital operator (part number 00F5060-1100).....	15
4.1.3	Interface operator (part number 00F5060-2000).....	15
4.1.4	Remote control	16
4.1.5	Other operators	16
4.2	Keyboard Operation.....	16
4.2.1	Parameter numbers and values	16
4.2.2	Resetting error messages	17
4.2.3	password input	17
5.	Parameter Descriptions	18
5.1	Basic/Compact/General/Application without encoder interface.....	18
A.	Annex A	24
A.1	Overload characteristic	24
A.2	Calculation of the motor voltage	24
A.3	Maintenance.....	24
A.4	Storage.....	25
A.5	Changing the response threshold of the braking transistor.....	26
B.	Annex B	27
B.1	CE-Marking	27
B.2	UL Marking.....	27
B.3	Additional Manuals	29

1. Safety and operating instructions



Safety and operating instructions for drive converters

(in conformity with the Low-Voltage Directive 2006/95/EC)

1. General

In operation, drive converters, depending on their degree of protection, may have live, uninsulated, and possibly also moving or rotating parts, as well as hot surfaces.

In case of inadmissible removal of the required covers, of improper use, wrong installation or maloperation, there is the danger of serious personal injury and damage to property.

For further information, see documentation.

All operations serving transport, installation and commissioning as well as maintenance are to be carried out by skilled technical personnel (Observe IEC 364 or CENELEC HD 384 or DIN VDE 0100 and IEC 664 or DIN/VDE 0110 and national accident prevention rules!).

For the purposes of these basic safety instructions, „skilled technical personnel“ means persons who are familiar with the installation, mounting, commissioning and operation of the product and have the qualifications needed for the performance of their functions.

2. Specified application

Drive converters are components designed for inclusion in electrical installations or machinery.

In case of installation in machinery, commissioning of the drive converter (i.e. the starting of normal operation) is prohibited until the machinery has been proved to conform to the provisions of the directive 2006/42/EC (Machinery Directive). Account is to be taken of EN 60204.

The drive converters meet the requirements of the Low-Voltage directive 2006/95/EC. The harmonized standards of the series EN61800-5-1 for the drive converters were used.

The technical data as well as information concerning the supply conditions shall be taken from the rating plate and from the documentation and shall be strictly observed.

3. Transport, storage

The instructions for transport, storage and proper use shall be complied with.

The climatic conditions shall be in conformity with EN 61800-5-1.

4. Installation

The installation and cooling of the appliances shall be in accordance with the specifications in the pertinent documentation.

The drive converters shall be protected against excessive strains. In particular, no components must be bent or isolating distances altered in the course of transportation or handling. No contact shall be made with electronic components and contacts.

Drive converters contain electrostatic sensitive components which are liable to damage through improper use. Electric components must not be mechanically damaged or destroyed (potential health risks).

5. Electrical connection

When working on live drive converters, the applicable national accident prevention rules (e.g. VBG 4) must be complied with.

The electrical installation shall be carried out in accordance with the relevant requirements (e.g. cross-sectional areas of conductors, fusing, PE connection). For further information, see documentation.

Instructions for the installation in accordance with EMC requirements, like screening, earthing, location of filters and wiring, are contained in the drive converter documentation. They must always be complied with, also for drive converters bearing a CE marking. Observance of the limit values required by EMC law is the responsibility of the manufacturer of the installation or machine.

6. Operation

Installations which include drive converters shall be equipped with additional control and protective devices in accordance with the relevant applicable safety requirements, e.g. act respecting technical equipment, accident prevention rules etc.. Changes to the drive converters by means of the operating software are admissible.

After disconnection of the drive converter from the voltage supply, live appliance parts and power terminals must not be touched immediately because of possibly energized capacitors. In this respect, the corresponding signs and markings on the drive converter must be respected.

During operation, all covers and doors shall be kept closed.

7. Maintenance and servicing

The manufacturer's documentation shall be followed.

KEEP SAFETY INSTRUCTIONS IN A SAFE PLACE!

2. Product description

2.1 Intended use

The frequency inverter KEB COMBIVERT F5 serves exclusively for the control and regulation of three-phase motors. The operation of other electric consumers is prohibited and can lead to the destruction of the unit.

Frequency inverters are components which are intended for the installation in electric systems or machines.

2.2 Unit identification

05	F5	B	3	A	0	A	0	A	Cooling A: Standard B: Flat rear
									Encoder interface 0: none
									Switching frequency; short time current limit; overcurrent limit 0: 2 kHz; 125%; 150% 9: 4 kHz; 180%; 216 % A: 8 kHz; 180%; 216 %
									Input identification 0: 1-phase 230VAC or DC supply 3: 3-phase 400VAC or DC supply 6: 1-phase 230V AC
									Housing type A
									Accessories 0: none 1: Braking transistor and temperature detection 2: Integrated filter ¹⁾ 3: Braking transistor, temperature detection and integrated filter ¹⁾
									Control type B: BASIC ²⁾
									Series F5
									Inverter size

- The integrated filter is only effective on L1, L2, L3 (not at DC operation).
- At control type "BASIC" (xxF5Bxx-xxxx) an output frequency of up to 1600 Hz is possible by changing the operating mode. This device is subject to export authorisation according to entry 3A225 Annex I of the Dual-Use Regulation.

Product description

2.3 Technical Data of the 230 V Class

Inverter size		05	07	
Housing size		A	A	
Phases		1	1	
Output rated power	[kVA]	0,9	1,6	
Max. rated motor power	[kW]	0,37	0,75	
Output rated current	[A]	2,3	4	
Output rated current UL	[A]	2	4,1	
Max. short time current	[A]	4,1	7,2	
OC-tripping current	[A]	5	8,6	
Rated switching frequency	[kHz]	4	4	8
Max. switching frequency	[kHz]	8	4	8
Power loss at nominal operating	[W]	30	55	60
Power loss at DC operating	[W]	28	51	56
Max. permissible main fuse gG	[A]	16	16	
Minimum braking resistor	[Ω]	100	100	
Maximal braking current	[A]	4,5	4,5	
Input rated current	[A]	4,6	8	
Rated input current UL	[A]	4	8	
Input rated voltage	[V]	230 (UL= 240)		
Input voltage range U _{in}	[V]	180...260 ±0		
Input voltage at DC operation	[V]	250...360		
Mains frequency	[Hz]	50...60 ±2		
Output voltage	[V]	3 x 0...U _{in}		
Output frequency	2) [Hz]	0...400		
Max. motor line length shielded	1) [m]	10 (Cat. C1)		
Max. motor line length shielded	[m]	35	50	

- 1) Considerable longer motor lines up to 25m are possible with ferrite rings (part number 0090396-2620) and low-capacity cable (phase/phase < 65pF/m, phase/shielding < 120pF/m) at the output - please contact KEB. Category C1 (formerly class B according to EN 55011) Category C2 (formerly class A according to EN 55011)
- 2) The real output frequency is depending of the parameterisation. The output frequency is to be limited in such way that 1/10 of the switching frequency is not exceeded. At control type "BASIC" (xxF5Bxx-xxxx) an output frequency of up to 1600 Hz is possible by changing the operating mode. This devices are subject to export authorisation according to entry 3A225 Annex I of the Dual-Use Regulation.



Site altitude maximal 2000 m above sea level. With site altitudes over 1000 m a derating of 1% per 100 m must be taken into consideration.

2.4 Technical Data of the 400 V Class

Inverter size		05	07	09
Housing size		A	A	A
Phases		3	3	3
Output rated power	[kVA]	0,9	1,8	2,8
Max. rated motor power	[kW]	0,37	0,75	1,5
Output rated current	[A]	1,3	2,6	4,1
Output rated current UL	[A]	1,0	1,8	3,4
Max. short time current	[A]	2,3	4,7	7,4
OC-tripping current	[A]	2,8	5,6	8,9
Rated switching frequency	[kHz]	4	4	4
Max. switching frequency	[kHz]	4	4	4
Power loss at nominal operating	[W]	45	50	60
Power loss at DC operating	[W]	44	48	58
Max. permissible main fuse gG	[A]	10	10	10
Minimum braking resistor	[Ω]	390	180	110
Typically braking resistor	[Ω]	620	300	150
Maximal braking current	[A]	2,2	4,5	7
Input rated current	[A]	1,8	3,6	6
Rated input current UL	[A]	1,4	2,5	4,8
Input rated voltage	[V]	400 (UL= 480)		
Input voltage range U _{in}	[V]	305...528 ±0		
Input voltage at DC operation	[V]	420...747		
Mains frequency	[Hz]	50...60 ±2		
Output voltage	[V]	3 x 0...U _{in}		
Output frequency	2) [Hz]	0...400		
Max. motor line length shielded	1) [m]	10 (Cat. C2)		
Max. motor line length shielded	[m]	15	40	50

- 1) Considerable longer motor lines up to 25m are possible with ferrite rings (part number 0090396-2620) and low-capacity cable (phase/phase < 65 pF/m, phase/shielding < 120 pF/m) at the output - please contact KEB. Category C1 (formerly class B according to EN 55011) Category C2 (formerly class A according to EN 55011)
- 2) The real output frequency is depending of the parameterisation. The output frequency is to be limited in such way that 1/10 of the switching frequency is not exceeded. Upto 1600 Hz are possible by changing the operating mode. Thus this devices are subject to export authorisation according to entry 3A225 Annex I of the Dual-Use Regulation.



Site altitude maximal 2000 m above sea level. With site altitudes over 1000m a derating of 1 % per 100m must be taken into consideration.

Product description

2.5 Dimensions and Terminals

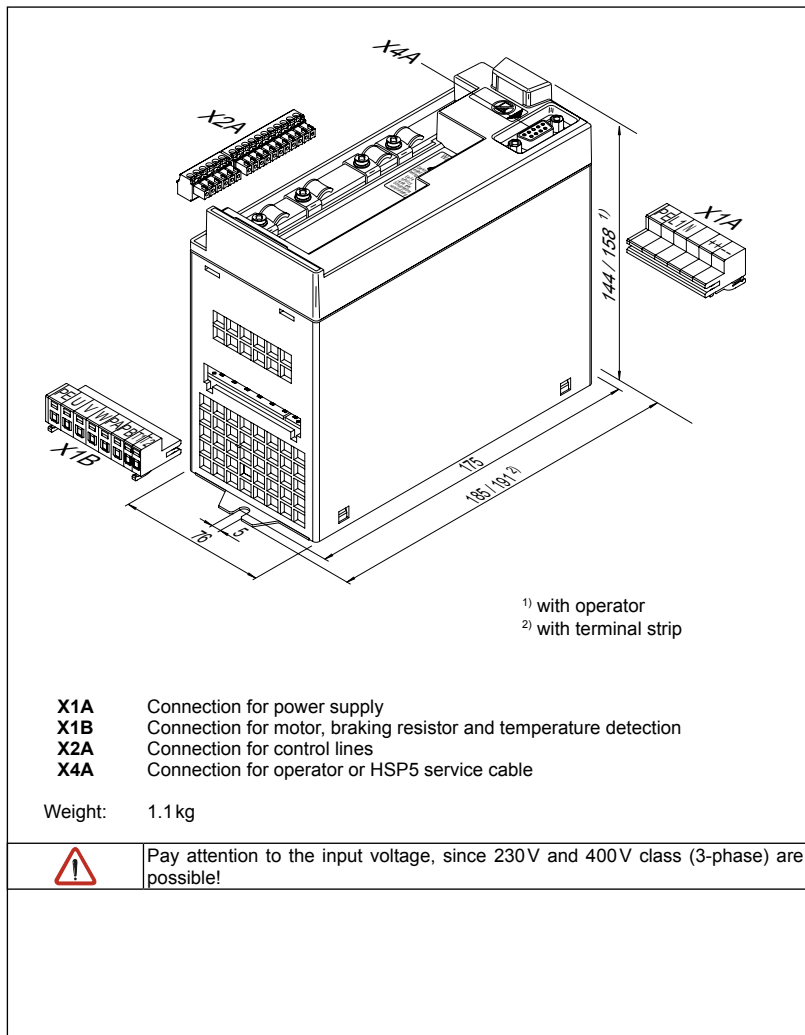

3. Installation and Connection

3.1 Control cabinet installation

Protective system (EN 60529):	IP20
Operation temperature ¹⁾ :	-10...45 °C (14...113 °F)
Storage temperature:	-25...70 °C (-13...158 °F)
max. heat sink temperature:	
Size 05/230 V	100 °C (212 °F)
Size 07/230 V	95 °C (203 °F)
Size 05...09/400 V	90 °C (194 °F)
Climatic category (EN60721-3-3):	3K3
Environment (IEC 664-1):	Pollution degree 2
Vibration/Jolt according to:	German. Lloyd; EN50155

Installation position and min. distances

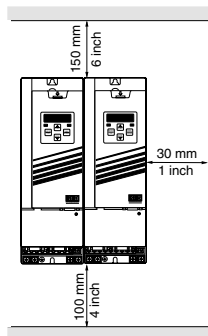

The flat-rear design requires cooling measures by the machine builder. The respective cooling measures depend on the operation conditions.



Protect the COMBIVERT against aggressive gases and aerosols !

¹⁾ At housing size 05/230 V and field bus operation max. 40 °C!

3.2 EMC-conform Installation

- Always apply the shielding of motor and control cables over a large contact surface on both sides.
- Distance between control and power cables at least 10...20 cm (4...8 inch).
- Lay motor and power cable separately.
- If it cannot be avoided, cross control and power cables in a right angle.
- Install all cables as close as possible to the mounting plate - ideal in a metal cable duct.
- Mount COMBIVERT well conducting with the mounting plate. Remove the paint beforehand.

You can find further instructions regarding the EMC-conform wiring in the Internet at KEB.

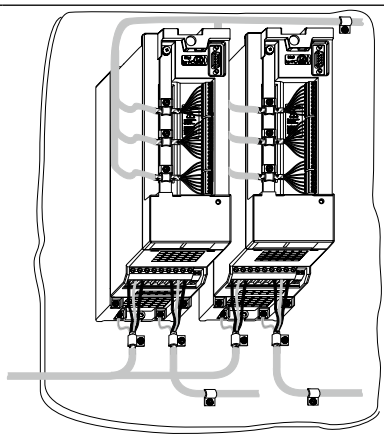

Installation and Connection

3.3 Connection of Power Circuit

3.3.1 Wiring instructions

- Core cross-section 1.5 mm²
- Strip 7mm
- Optional use of wire-end ferrule
- After arresting the cable by removing the screwdriver absolutely check for a firm fit

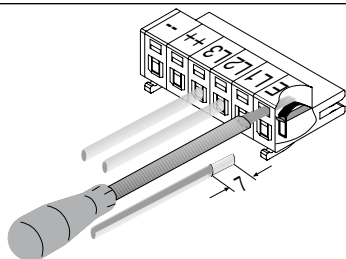

Attach / remove terminal strip only at tensionless state

3.3.2 Mains connection terminal strip X1A

Mains connection 230V 1-phase

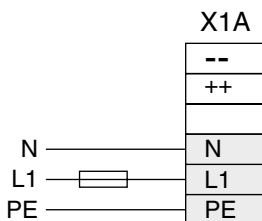

Mains connection 400V 3-phase

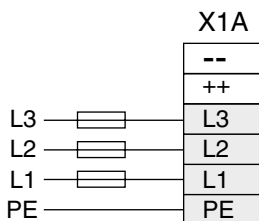

- Fuse (see chapter 2.3) or power protective switch
- 1-phase inverter RCD type A or type B
- 3-phase inverter RCMA with separator or RCD type B
- at DC-supply pay attention to the permissible voltage range of the fuses

DC connection

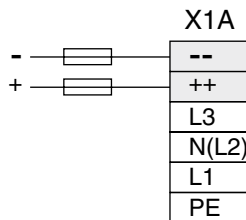

Absolutely observe the connecting voltage of the KEB COMBIVERT. A 230V-unit will be immediately destructed on a 400V-power supply.



Never exchange the mains and motor cables.



Some countries demand that the PE-terminal is directly connected to the terminal box (not over the mounting plate).

3.3.3 Terminal strip X1B

- PE Connection for earthing
- U, V, W Motor connection
- PA, PB Braking resistor
- T1, T2 Temperature sensor / switch

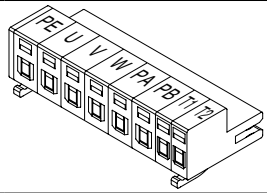

3.3.4 Motor connection



- Observe correct phase sequence of the motor!
- Maximum motor line length see chapter 2.3

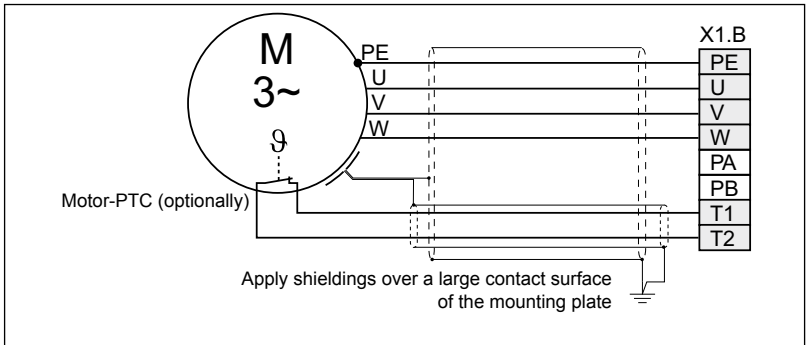

3.3.5 Connection of the temperature monitoring

- Terminals T1, T2
- Tripping resistance 1.65...4 kOhm
- Reset resistance 0.75...1.65 kOhm
- Design in accordance with VDE 0660 Part 302
- This function can be activated by the machine builder by software
- Do not lay connecting cable together with control cable
- Permissible in the motor cable only with double shielding
- Connect relay K1 for fire prevention in regenerative operation (see 3.3.6)

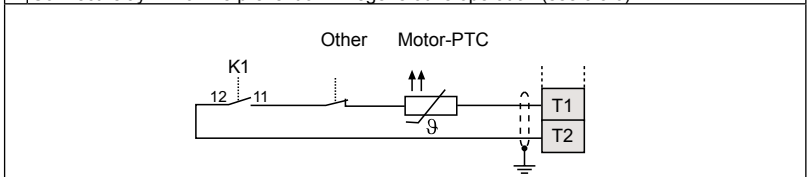

Installation and Connection

3.3.6 Connection of a braking resistor with temperature monitoring in accordance with UL

- PA, PB Connector for braking resistor
- Technical data (see chapter 2.3)
- During clearing of the temperature monitoring the input voltage is switched off
- For additional protection in regenerative operation connect the auxiliary contacts 11 and 12 of the line contactor K1 (see 3.3.5)



With input rated voltage of 480 Vac no braking resistor shall be connected.

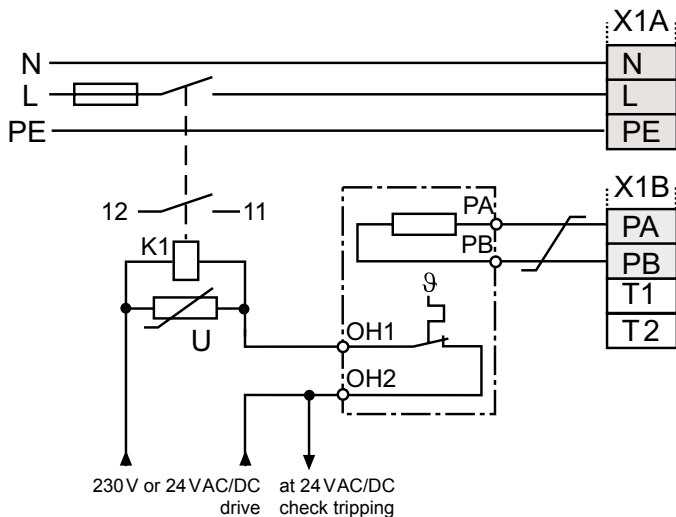

Braking resistors can develop very high surface temperatures, therefore install as safe-to-touch as possible.

3.4 Control Board Basic

3.4.1 X2A Control terminal strip

<ul style="list-style-type: none"> • Tightening torque 0.22...0.25 Nm (2 lb inches) • Use shielded/drilled cables • Lay shield on one side of the inverter onto earth potential 	X2A

PIN	Function	Name	Explanation
1	+ Setpoint input	AN1+	Difference voltage 0...±10VDC; Ri = 30 kΩ
Programmable analog output			0...±10VDC (max. 5 mA)
5	Analog output	AO1	Output of the actual output frequency 0...±100Hz => 0...±10VDC (max. 5 mA)
7	+10V output	CRF	Reference voltage for setpoint poti +10VDC / max. 4 mA
8	Analog Mass	COM	Mass for analog in- and outputs
Programmable digital inputs			13...30VDC ±0% smoothed Ri: 2.1 kΩ; scan time: 2ms
10	Fixed frequency 1 (CP.19)	I1	I1 + I2 = fixed frequency 3 (CP.21)
11	Fixed frequency 2 (CP.20)	I2	
14	Forward	F	Rotation selection
15	Reverse	R	Forward has priority
16	Control release / Reset	ST	Power modules are enabled; error reset at opening
20	24V - output	Uout	Supply of the digital inputs (24VDC/ max. 100 mA)
22	Digital Mass	0V	Reference potential for digital inputs/outputs
Relay outputs			Load capacity max. 30VDC / 0.01...1A
24	Relay 1 / NO contact	RLA	Programmable relay output (CP.31) Factory setting: Fault relay
25	Relay1 / NC contact	RLB	
26	Relay1 / switching contact	RLC	
27	Relay 2 / NO contact	FLA	Programmable relay output (CP.32) Factory setting: Frequency dependent switch
28	Relay 2 / NC contact	FLB	
29	Relay 2 / switching contact	FLC	

Installation and Connection

3.4.2 Connection of the control terminal strip

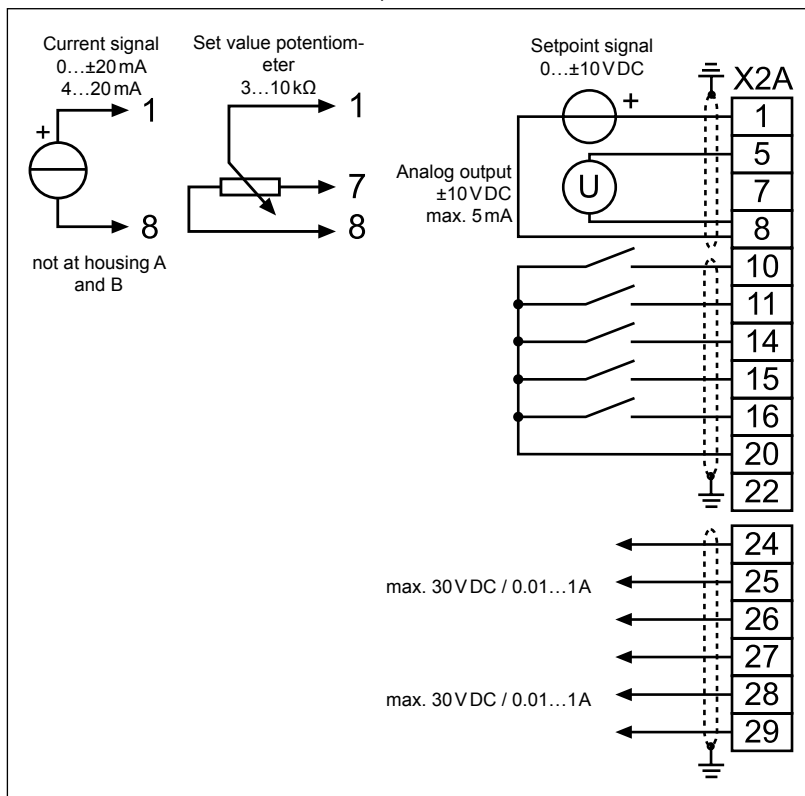

To avoid interferences a separate shielding must be provided for analog and digital control lines. Depending on the use of the relay outputs, an extra shielding is to be used, too.



In case of inductive load on the relay outputs a protective wiring must be provided (e.g. free-wheeling diode)!



The terminals of the control terminal strip and the transmitter inputs are securely isolated in accordance with EN 50178.

4. Operation of the Unit

4.1 Operation Accessories

4.1.1 With HSP5 cable and without operator

A special cable (part number .00F50C0.-0001) is necessary for the control of the KEB COMBIVERT without operator. It is connected between the HSP5-interface X4A and a serial RS232-PC-interface (COM1 or COM2). The operation takes place via the PC-program COMBIVIS.



The HSP5-cable has an integrated level converter. The connection of a serial standard cable would destroy the PC-interface.

4.1.2 Digital operator (part number 00F5060-1100)

As an accessory for the local operation of the KEB COMBIVERT F5 an operator is available. To prevent malfunctions, the inverter must be brought into nOP status before connecting / disconnecting the operator (open control release). When starting the inverter, it is always started with the last stored values or the factory setting.

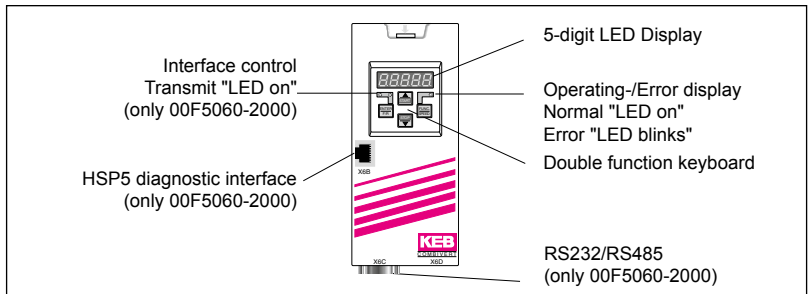

4.1.3 Interface operator (part number 00F5060-2000)

The interface operator corresponds to the functional range of the digital operator. However, it is enhanced by a serial RS232/485-interface.

PIN	RS485	Signal	Meaning
1	-	-	reserved
2	-	TxD	transmission signal RS232
3	-	RxD	receive signal RS232
4	A'	RxD-A	receive signal A RS485
5	B'	RxD-B	receive signal B RS485
6	-	VP	Voltage supply +5V (I _{max} =50 mA)
7	C/C'	DGND	Data reference potential
8	A	TxD-A	transmission signal A RS485
9	B	TxD-B	transmission signal B RS485

A RS232-cable is needed to connect the interface operator with the PC. The assignment is represented on the following page.

Operation of the Unit

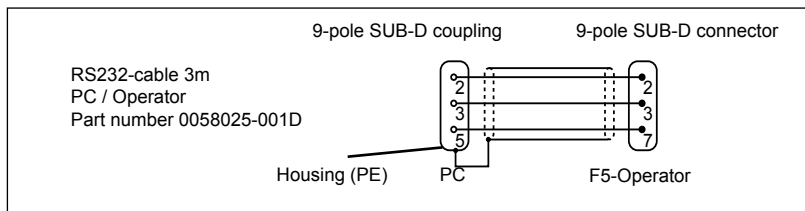

4.1.4 Remote control

For remote control of the KEB COMBIVERT F5 a special HSP5 operator is available.

Operator	Cable	The last three digits of the part number indicate the length of the cable in dm.
00F5060-9000	00F50C0-2xxx	
00F5060-9001	00F50C0-3xxx	

4.1.5 Other operators

In addition to the described operators the KEB COMBIVERT can be equipped with further operators for special applications (Profibus, Interbus, Sercos, CAN, DeviceNet). You find further information on that on our home page.

4.2 Keyboard Operation

4.2.1 Parameter numbers and values

When switching on KEB COMBIVERT F5 the value of parameter CP.1 appears.

The function key changes between the parameter value and parameter number.



With UP (▲) and DOWN (▼) the value of the parameter number is increased/decreased with changeable parameters.



Principally during a change, parameter values are immediately accepted and stored non-volatile. However, with some parameters it is not useful that the adjusted value is accepted immediately. In these cases the adjusted value is accepted and stored non-volatile by pressing ENTER. When this type of parameter is changed a point appears behind the last digit.

By pressing „ENTER“ the adjusted value is accepted and non-volatile stored.



4.2.2 Resetting error messages

If a malfunction occurs during operation, then the actual display is overwritten by the alarm message. The alarm message in the display is reset by ENTER.



With ENTER only the error message in the display is reset. In order to reset the error itself, the cause must be removed or a power-on reset must be made.

4.2.3 password input

The KEB COMBIVERT is outfitted with a comprehensive password protection. In dependence on the entered password the following modes are possible:

Display	Mode
CP_ro	End customer menu (CP-Parameter) read-only
CP_on	End customer menu (CP-Parameter) read/write
CP_SE	Service menu (like end customer menu, but with the original parameters)
APPL	Application menu (all parameter groups and parameters are visible)
-	Drive mode (COMBIVERT can be put into operation by the keyboard)

The menu admissible for the application is defined by the machine builder. The password input is generally made over the parameter CP.0. The adjusted password/menu is maintained even after switching off.

Example: Changing the CP-parameter from read-only to read/write

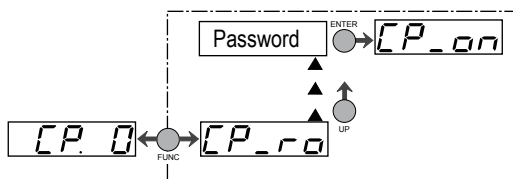

CP-Parameters

5. Parameter Descriptions

5.1 Basic/Compact/General/Application without encoder interface

Parameter	Setting range	Resolution	Default	Unit	┘	Based on
CP.0	password input	0...9999	1	-	-	ud.1
CP.1	Actual frequency display	-400...400	0,0125	0	Hz	ru.3
CP.2	Set frequency display	-400...400	0,0125	0	Hz	ru.1
CP.3	Inverter status	0...255	1	0	-	ru.0
CP.4	apparent current	0...6553,5	0,1	0	A	ru.15
CP.5	peak apparent current	0...6553,5	0,1	0	A	ru.16
CP.6	Utilization	0...65535	1	0	%	ru.13
CP.7	actual DC voltage	0...1000	1	0	V	ru.18
CP.8	DC link voltage / peak value	0...1000	1	0	V	ru.19
CP.9	Output voltage	0...778	1	0	V	ru.20
CP.10	Minimal frequency	0...400	0,0125	0	Hz	op.6
CP.11	Maximum frequency	0...400	0,0125	70	Hz	op.10
CP.12	acc. time for.	0,00...300,00	0,01	5	s	op.28
CP.13	Deceleration time (-1=CP.12)	-0,01...300,00	0,01	5	s	op.30
CP.14	S-curve time	0,00...5,00	0,01	0	s	op.32
CP.15	Boost	0,0...25,5	0,1	LTK	%	uf.1
CP.16	rated frequency	0...400	0,0125	50	Hz	uf.0
CP.17	Voltage stabilization	0...650 V (off)	1	0	V	E uf.9
CP.18	switching frequency	0...LTK	1	LTK	-	E uf.11
CP.19	Fixed frequency 1	-400...400	0,0125	5	Hz	op.21
CP.20	Fixed frequency 2	-400...400	0,0125	50	Hz	op.22
CP.21	Fixed frequency 3	-400...400	0,0125	70	Hz	op.23
CP.22	DC braking / mode	0...9	1	7	-	E pn.28
CP.23	DC braking time	0,00...100,00	0,01	10	s	pn.30
CP.24	Max. ramp current	0...200	1	140	%	pn.24
CP.25	Max. constant current	0...200	1	200:off	%	pn.20
CP.26	Speed search / condition	0...15	1	8	-	E pn.26
CP.27	Quick stopping / ramp time	0,00...300,00	0,01	2	s	pn.60
CP.28	Response of ext. overtemperature.	0...7	1	7	-	pn.12
CP.29	Analog output 1 / function	0...20	1	2	-	E an.31
CP.30	Analog output 1 / amplification	-20,00...20,00	0,01	1	-	an.33
CP.31	relay output 1 / function	0...76	1	4	-	E do.2
CP.32	relay output 2 / function	0...76	1	27	-	E do.3
CP.33	Relay output 2 / function	±30000,00	0,01	4	-	le.3
CP.34	Source of rotation direction	0...9	1	2	-	E op.1
CP.35	AN1 set value selection	0...2	1	0	-	E an.0
CP.36	AN1 zero point hysteresis	-10,0...10,0	0,1	0,2	%	an.4

LTK=depending on power unit; E=ENTER parameter

CP.3 inverter state

In parameter „inverter status“ the actual operating condition of the frequency inverter is displayed. In the case of an error the current error message is displayed, even if the display has already been reset with ENTER (error-LED on the operator is still blinking).

nOP	„no Operation“; control release not bridged; modulation switched off; output voltage = 0V; drive is not controlled
LS	„Low Speed“; no direction of rotation preset; modulation switched off; output voltage = 0V; drive is not controlled
FAcc	„Forward Acceleration“; drive accelerates with direction of rotation forward
FdEc	„Forward Deceleration“; drive decelerates with direction of rotation forward
rAcc	„Reverse Acceleration“; drive accelerates with direction of rotation reverse
rdEc	„Reverse Deceleration“; drive decelerates with direction of rotation reverse
Fcon	„Forward Constant“; drive runs with constant speed and direction of rotation forward
rcon	„Reverse Constant“; drive runs with constant speed and direction of rotation reverse

Status messages and information about the cause and removal are to be found at the „Standard- and Interface Operator“ instruction manual.

CP.17 Voltage stabilization

With this parameter a regulated output voltage in relation to the rated frequency can be adjusted. For that reason voltage variations at the input as well as in the intermediate circuit only have a small influence on the output voltage (U/f-characteristic). The function allows, among other things, an adaption of the output voltage to special motors.

CP.22 DC braking / mode

With DC-braking the motor is not decelerated by the ramp. Quick braking is caused by D.C. voltage, which is applied onto the motor winding. This parameter determines how the dc-braking is triggered.

Value	Activation
0	DC-braking deactivated
1	DC-braking at switch off of the direction of rotation and upon reaching 0Hz. The braking time is CP.23 or until the next direction of rotation.
2*	DC-braking as soon as setting for the direction of rotation is absent.
3*	DC-braking as soon as the direction of rotation changes or is absent.
4*	DC-braking at switch off of the direction of rotation and upon reaching 4Hz.
5*	DC-braking when the real frequency falls below 4 Hz and the drives decelerates
6*	DC-braking as soon as the set value falls below 4Hz.
7*	DC-braking when input I4 is switched (control board B = „0“)
8	DC-braking as long as input I4 is switched (control board B = „0“)
9	DC-braking after switching on the modulation.

* Braking time depends on the actual frequency.

CP.24 Max. ramp current

This function protects the frequency inverter against switching off through overcurrent during the acceleration ramp. When the ramp reaches the adjusted value, it is stopped so long until the current decreases again. CP.3 displays "LAS" at active function.

CP-Parameters

CP.25 Max. constant current

This function protects the frequency inverter against switch off through overcurrent during constant output frequency. When exceeding the adjusted value, the output frequency is reduced until the value drops below the adjusted value. CP. 3 displays "SSL" at active function.

CP.26 Speed search / condition

When connecting the frequency inverter onto a decelerating motor, an error can be triggered by the differing rotating field frequencies. With activated speed search the inverter searches for the actual motor speed, adapts its output frequency and accelerates with the adjusted ramp to the given set value. During speed search CP.3 displays "SSF". The parameter determines, under what conditions the functions operate.

In case of several conditions the sum of the value must be entered. Example: CP.26 = 12 means after reset **and** after auto-reset UP.

Value	Condition
0	Function off
1	at control release
2	at switch on
4	after reset
8	after Auto-Reset UP

CP.28 Response of external overtemperature

CP.28 determines the response of the drive on the external temperature monitoring. At factory setting the function is switched off. In order to activate this function the power circuit terminals T1/T2 must be connected. After that the response can be adjusted according to following table. If overheat no longer exists, the message E.ndOH (or A.ndOH) is output. Only then the error can be reset or the automatic restart can be carried out.

CP.28	Display	Reaction	Restart
0	E.dOH	Immediate disabling of modulation	
1*	A.dOH	Quick stop / disabling the modul. after reaching speed 0	Remove fault; reset
2*	A.dOH	Quick stopping / holding torque at speed 0	
3	A.dOH	Immediate disabling of modulation	
4*	A.dOH	Quick stop / disabling the modul. after reaching speed 0	Autoreset, if no fault is present
5*	A.dOH	Quick stopping / holding torque at speed 0	
6*	none	No effect to the drive; With CP.31/32 an external module can be controlled (e. g. fan)	inapplicable
7	none	No effect to the drive; Malfunction is not present! External temperature monitoring is not activated.	

*) If the motor is still too hot after 10 seconds, the error E.dOH is triggered and the modulation is switched off!

CP.29 Analog output 1 / function

CP.29 defines the function of analog output 1.

Value	Function	Scaling factor 0...100% (0...±100%)
0	Absolute actual frequency CP.3	0...100Hz

1	absolute set frequency CP.2	0...100Hz
2	actual frequency CP.3	0...±100Hz
3	Setpoint frequency CP. 2	0...±100Hz
4	output voltage CP.9	0...500V
5	DC link voltage CP.7	0...1000V
6	apparent current CP.4	0...2 • rated current
7	active current ru.17	0...2 • ±rated current
8...10	only application mode	
11	absolute active current ru.17	0...2 • rated current
12	power stage temperature ru.38	0...100 °C
13	motor temperature ru.46	0...100 °C
14...18	only application mode	
19	ramp output frequency ru.2	0...±100Hz
20	absolute ramp output frequency ru.2	0...100Hz

CP.31 Relay output 1 / function (terminals X2A.24...26)

CP.32 Relay output 2 / function (terminals X2A.27...29)

The switching level of CP.31 is pre-set to 100.00.

The switching level of CP.32 is adjusted by CP.33!

Value	Function
0	No function (generally off)
1	Generally on
2	run; also at DC-braking
3	ready (no error)
4	Fault relay
5	Fault relay (without auto-reset)
6	Warning or error message at abnormal stopping
7	OL warning
8	OH warning
9	External Overtemperature alert signal motor
11	Overtemperature alert signal interior OHI
12	Cable breakage 4...20 mA on analog input 1
14	max. constant current (Stall, CP.25) exceeded
15	max. ramp current (LA-Stop, CP.24) exceeded
16	DC-braking active
20	Actual value = set value (CP.3 = Fcon; rcon; not at noP, LS, error, SSF)
21	acceleration (CP.3 = FAcc, rAcc, LAS)
22	deceleration (CP.3 = FdEc, rdEc, LdS)
23	act. rotation = set rotation
24	Utilization (CP.6) > switching level
25	Active current > switching level
26	Intermediate circuit voltage (CP.7) > switching level
27	Real value (CP.1) > switching level
28	Set value (CP.2) > switching level
31	Absolute set value at AN1 > switching level
32	Absolute set value at AN2 > switching level
34	Set value at AN1 > switching level

CP-Parameters

35	Set value at AN2 > switching level
40	hardw.curr. limit active
41	modulation on
44	Inverter status > switching level
45	Power stage temperature > switching level
46	Motor temperature > switching level
47	Ramp output value > switching level
48	Apparent current (CP,4) > switching level
49	rot. forward (not at nOP, LS, abnormal stopping or error)
50	rot. reverse (not at nOP, LS, abnormal stopping or error)
63	Absolut ANOUT1 > switching level
64	Absolut ANOUT2 > switching level
65	ANOUT1 > switching level
66	ANOUT2 > switching level
70	Driving current active (safety relay)
73	Absolute active power > switching level
74	Active power > switching level

No listed values are only for application mode.

CP.34 Source of rotation direction

The source rotation setting and the mode of evaluating the rotation setting is defined with this parameter (Enter-Parameter). With CP.34 one does not modify the rotation source of the fixed frequencies (CP.19...21).

Value	Direction of rotation
0/1	only application mode
2	Setting by way of terminal strip forward/reverse; negative set values are set to zero (factory setting)
3	Setting by way of terminal strip forward/reverse; the sign of the set point values have no effect on direction of rotation
4	Setting by way of terminal strip run/stop (X2A.14) and forward/reverse (X2A.15); negative values are set to zero
5	Setting by way of terminal strip run/stop (X2A.14) and forward/reverse (X2A.15); the sign of the set point values have no effect on direction of rotation
6	Set value dependent, positive value = clockwise rotation; negative value-counter-clockwise rotation; Status "Low speed" (LS) if no terminal For or Rev is active
7	Set value dependent, positive value = clockwise rotation; negative value = counter-clockwise rotation clockwise rotation is indicated if set value is "0"
8/9	only application mode

CP.35 AN1 set value selection

The setpoint input 1 (AN1) at the F5-GENERAL/COMPACT control can be driven by various signal levels. In order to correctly evaluate the signal, this parameter must be adapted to the signal source. At F5 Basic control board at housing type A or B the signal source may not be re-adjusted.

Value	Set value signal
0	0...±10VDC / GENERAL/COMPACT Ri = 55 kΩ / BASIC Ri = 30 kΩ
1	0...±20mADC / Ri = 250 Ω
2	4...20mADC / Ri = 250 Ω

A. Annex A

A.1 Overload characteristic

Release time [s]

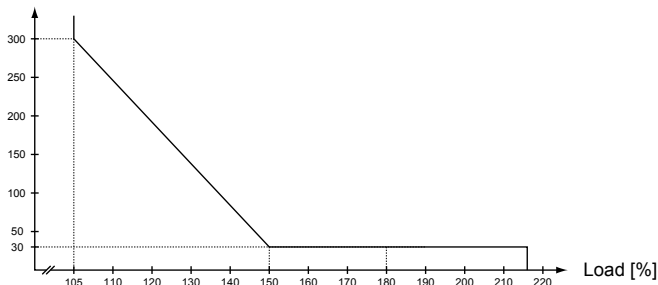

On exceeding a load of 105% the overload integrator starts. When falling below the integrator counts backwards. Error E.OL is triggered if the integrator achieves the overload characteristic.

A.2 Calculation of the motor voltage

The motor voltage for dimensioning of the drive is depending on the used components. The mains voltage reduces according to the following table:

Mains choke Uk	4%	Example:
Inverter open loop	4%	Closed loop inverter with mains- and motor choke at
Inverter closed loop	8%	non-rigid supply system:
Motor choke Uk	1%	400V mains voltage - 15% = 340V motor voltage
Non-rigid supply system	2%	

A.3 Maintenance

All work may only be done by qualified personnel. The security must be ensured as follows:

- Disconnect power supply at MCCB
- Secure against restarting
- Await discharge time of capacitors (if necessary controlling by measurement at „+PA“ and „-“, respectively „++“ and „--“)
- Ensure loss of voltage by measurement

In order to avoid premature ageing and avoidable malfunctions, the measures mentioned below must be carried out in the appropriate cycle.

Cycle	Function
Constant	Pay attention to unusual noises of the motor (e.g. vibrations) as well as of the frequency inverter (e.g. fan).
	Pay attention to unusual smells of the motor or frequency inverter (e.g. evaporation of capacitor electrolyte, braise of the motor winding)
Monthly	Check unit for loose screws and plugs and if necessary tighten up.
	Clean frequency inverter from dirt and dust deposits. Pay attention especially to cooling fins and protective grid of the fans.
	Examine and clean extracted air filter and cooling air filter of the control cabinet.
	Examine function of the fans of the KEB COMBIVERT. The fans must be replaced in case of audible vibrations or squeak.

A.4 Storage

The DC link of the KEB COMBIVERT is equipped with electrolytic capacitors. If electrolytic capacitors are stored de-energized, the oxide film working as dielectric fluid reacts with the acidic electrolyte and destroy themselves slowly. This affects the dielectric strength and the capacity.

If the capacitor starts running with rated voltage, it is tried to build the oxide film abrupt again. This causes heat and gas and leads to the destruction of the capacitor.

In order to avoid defectives, the KEB COMBIVERT must be started up depending on the storage period in accordance with the following specification:

Storage period < 1 year			
•	Start-up without special measures		
Storage period 1...2 years			
•	Operate frequency inverter one hour without modulation		
Storage period 2...3 years			
•	Remove all cables from the power circuit; especially of braking resistor or module		
•	Open control release		
•	Connect variable transformer to inverter input		
•	Increase variable transformer slowly to indicated input voltage (>1 min) and remain at least on the specified time.		
	Voltage class	Input voltage	Residence time
	230 V	0...160 V	15 min
		160...220 V	15 min
		220...260 V	1 h
	400 V	0...280 V	15 min
		280...400 V	15 min
		400...540 V	1 h
further on next side			

Annex A

Storage period > 3 years

- Input voltages as before, however double the times per year. Eventually change capacitors. Eventually change capacitors.

After expiration of this start-up the KEB COMBIVERT can be operated on nominal rating conditions or delivered to a new storage.

A.5 Changing the response threshold of the braking transistor (not valid for control type „BASIC“)

To prevent a premature switching of the brake transistor at input rated voltage of 480 Vac, the response threshold must be adjusted according to the following diagram.

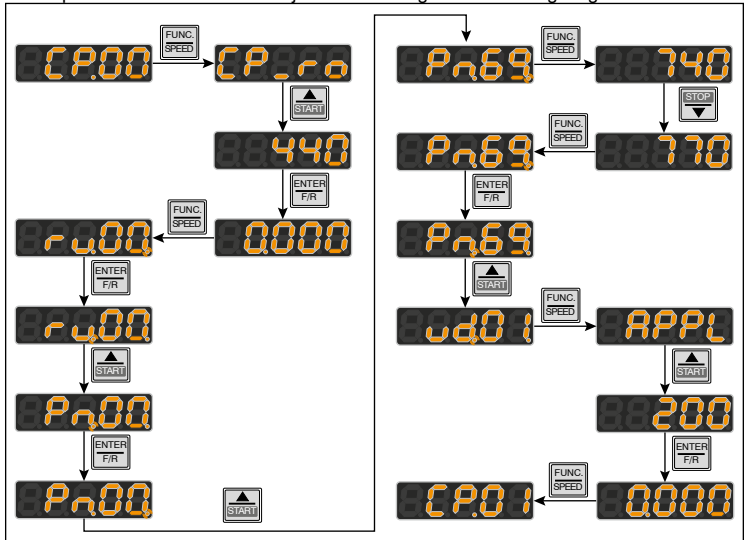

B. Annex B

B.1 CE-Marking

CE marked frequency inverter and servo drives were developed and manufactured to comply with the regulations of the Low-Voltage Directive 2006/95/EC.

The inverter or servo drive must not be started until it is determined that the installation complies with the Machine directive (2006/42/EC) as well as the EMC-directive (2004/108/EC)(note EN 60204).

The frequency inverters and servo drives meet the requirements of the Low-Voltage Directive 2006/95/EC. The harmonized standards of the series EN61800-2 were used.

This is a product of limited availability in accordance with IEC61800-3. This product may cause radio interference in residential areas. In this case the operator may need to take corresponding measures.

B.2 UL Marking

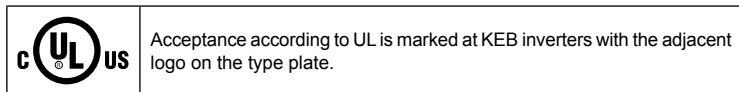

To be conform according to UL for use on the North American Market the following instructions must be observed (original text of the UL-File):

- 240V units
Suitable For Use On A Circuit Capable Of Delivering Not More Than 10kA rms Symmetrical Amperes, 240 Volts Maximum when Protected by Fuses or see Instruction Manual for Alternate BCP.
- 480V units
Suitable For Use On A Circuit Capable Of Delivering Not More Than 10kA rms Symmetrical Amperes, 480 Volts Maximum when Protected by Fuses or see Instruction Manual for Alternate BCP.
- Maximum Surrounding Air Temperature 45°C (113°F)
- For control cabinet mounting as „Open Type“
- Use in a pollution degree 2 environment
- Use 60/75°C Copper Conductors Only
- Motor protection by adjustment of current parameters.For adjustement see application manual parameters Pn.14 and Pn.15.
- Not incorporated Overspeed Protection
- Overload protection at 130 % of inverter output rated current (see type plate)
- Integral solid state short circuit protection does not provide branch circuit protection. Branch circuit protection must be provided in accordance with the Manufacturer Instructions, National Electrical Code and any additional local codes, or the equivalent.

Table for input fusing of inverters F5-A housing:

Annex B

Inverter	Input Voltage	UL 248 Fuse Class J or RK5 *	UL 248 Fuse Class CC *)
	[V]	[A]	[A]
05F5	240 /1ph	10	10
05F5	240 /1ph	6	5
07F5	240 /1ph	15	20
07F5	240 /1ph	10	10
05F5	400 / 480 / 3ph	5	---
07F5	400 / 480 / 3ph	6	---
09F5	400 / 480 / 3ph	10	---

*) The voltage rating of the Class rated fuses (CC, J or RK5) shall be at least equal to the voltage of the Drivers.

Branch Circuit Protection: Type E Self Protected Manual Motor Controllers for inverters F5-A housing.

Cat. No.	Drive Input rating	Self Protected Manual Motor Controller Type and manufacturer	Self Protected Manual Motor Controller rating
05F5	240V/ 1ph	PKZMO-10E, Eaton Industries	230V, 1.5 hp
05F5	240V/ 3ph	PKZMO-6.3E, Eaton Industries	230V/ 3ph, 1.5 hp
07F5	240V/ 3ph	PKZMO-16E, Eaton Industries	230V, 2 hp
07F5	240V/ 1ph	PKZMO-10E, Eaton Industries	230V/ 3ph, 3 hp

Cat. No.	Drive Input rating #	Self Protected Manual Motor Controller Type and manufacturer	Self Protected Manual Motor Controller rating
05F5	400 / 480V / 3ph	PKZMO-6.3E, Eaton Industries	480Y/277V, 3 hp
07F5	400 / 480V / 3ph	PKZMO-10E, Eaton Industries	480Y/277V, 7.5 hp
09F5	400 / 480V / 3ph	PKZMO-10E, Eaton Industries	480Y/277V, 7.5 hp

all Drives series which use a Self Protected Motor Controller rated 480Y / 277V are suitable for 480Y / 277V source only.

B.3 Additional Manuals

You find supplementary manuals and instructions for the download under

www.keb.de > Service > Downloads

General instructions

- Part 1 EMC-and safety instructions

Unit-specific instructions

- Part 2 Power Circuit
- Part 3 Control Circuit

Service notes

- Up- /Download of parameter lists with KEB COMBIVERT
- Error messages

Instruction and information for construction and development

- Application Manual
- Preparation of a user-defined parameter menu
- Programming of the digital inputs
- UL input fusing for COMBIVERT F5

Approvals and approbations

- Declaration of conformity CE
- UL-Yellow Card (<http://www.ul.com>)



Automation with Drive

www.keb.de

KEB Automation KG Suedstrasse 38 32683 Barntrup Germany Tel. +49 5263 401-0 E-Mail: info@keb.de