

SB2 beam load cell

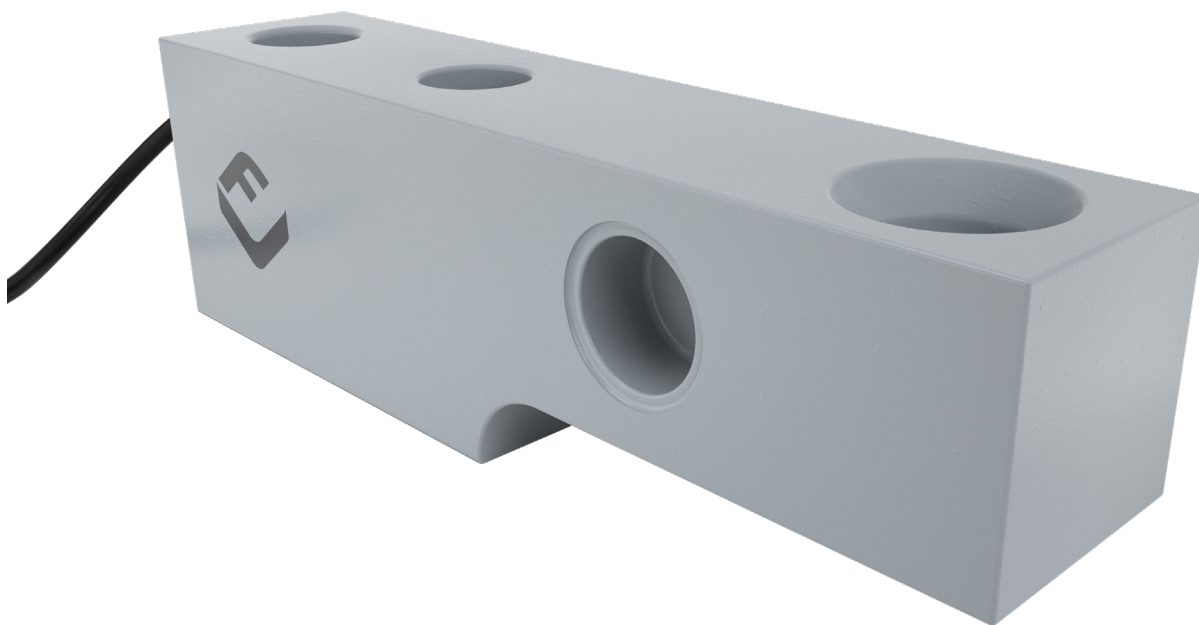

product description

Heavy duty shear beam load cell range designed specifically for applications found in steel processing systems. The SB2 design is particularly robust and is the choice for high capacity ladle weighing systems, coil weighers and platform scales. Hermetic sealing and resistant paint coating permits the SB2 to be used in the toughest of environments.

applications

High capacity industrial platform scales, ladle weighing systems and coil weighing systems.

key features

Tool steel construction

Hermetically sealed to IP68

Painted finish

High capacity beam up to 45t

Unique blind loading hole

Calibration in mV/V/Ω

approvals

OIML approval to C1 (Y = 5,000) and C3 (Y = 15,000)

ATEX hazardous area approval for zones 0, 1, 2, 20, 21 and 22

FM hazardous area approval

accessories

Compatible range of hardware

Compatible range of electronics



RoHS compliant



specifications

Maximum capacity (E_{max})	lb	45,000 / 100,000		
Metric equivalents (1 lb=0.45359 kg)	t	20.4 / 45.4		
Accuracy class according to OIML R60		GP	C1	C3
Maximum number of verification intervals (n_{max})		n.a.	1,000	3,000
Minimum load cell verification interval (v_{min})		n.a.	$E_{max} / 5,000$	$E_{max} / 15,000$
Temperature effect on minimum dead load output (TC_0)	%*RO/10°C	± 0.0400	± 0.0275	± 0.0122
Temperature effect on sensitivity (TC_{RO})	%*RO/10°C	± 0.0200	± 0.0160	± 0.0100
Combined error	%*RO	± 0.0500	± 0.0300	± 0.0200
Non-linearity	%*RO	± 0.0400	± 0.0300	± 0.0166
Hysteresis	%*RO	± 0.0400	± 0.0300	± 0.0166
Creep error (30 minutes) / DR	%*RO	± 0.0600	± 0.0490	± 0.0166
Rated Output (RO)	mV/V	2 ± 0.1%		
Calibration in mV/V/Ω (A...I classified)	%	± 0.05 (± 0.005)		
Zero balance	%*RO	± 5		
Excitation voltage	V	5...15		
Input resistance (R_{LC})	Ω	385 ± 20		
Output resistance (R_{out})	Ω	351 ± 1		
Insulation resistance (100 V DC)	MΩ	≥ 5,000		
Safe load limit (E_{lim})	%* E_{max}	200		
Ultimate load	%* E_{max}	300		
Safe side load	%* E_{max}	100		
Compensated temperature range	°C	-10...+40		
Operating temperature range	°C	-40...+80 (ATEX -40...+60)		
Load cell material		tool steel; painted		
Sealing		cable entry hermetic sealing by glass to metal header		
Protection according EN 60 529		IP68 (up to 2 m water depth) / IP69K		
Packet weight	kg	11.8 (45klb), 36.8 (100klb)		

The limits for Non-Linearity, Hysteresis, and TC_{RO} are typical values. The sum of Non-linearity, Hysteresis and TC_{RO} meets the requirements according to OIML R60 with $p_{LC}=0.7$.

product dimensions (mm)

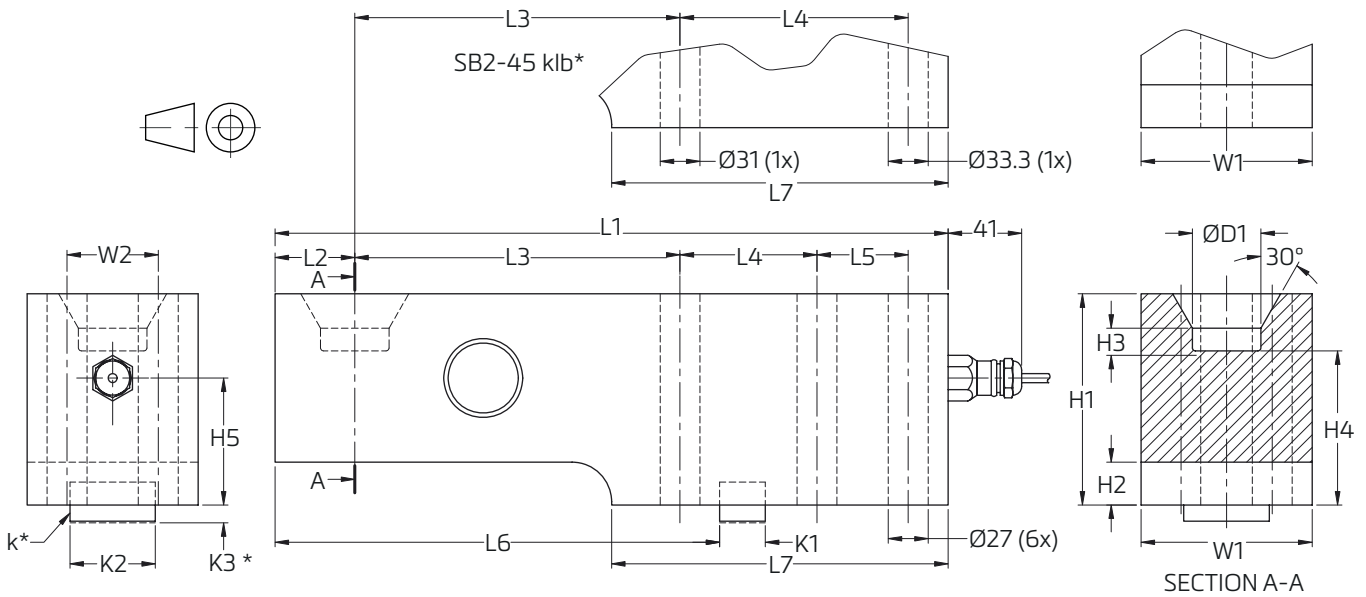

Type	L1	L2	L3	L4	L5	L6	L7	H1	H2	H3	H4	H5	W1	W2	D1	K1	K2	K3*	Mount bolts	Torque*
SB2-45 klb							159	95	27		73	61								
SB2-45 klb-M	318	38	159	89	-	-	148	82	12	12	58	47	70	-	38.1	-	-	-	M30 8.8	1500 Nm
SB2-100 klb	416	48	197	92	54	276	210	143	41	14	111	92	95	54	50.8	25.4	47.6	10	M24 8.8	750 Nm

Torque* - values assume oiled threads.

K3* - depth of key slot

SB2-45klb* - Only two holes for the 45lbs version

k* -Key

wiring

The load cell is provided with a shielded, 4 conductor cable (AWG 20).

Cable jacket polyurethane

Cable length: 9.1 m for 45 klb, 10.7 m for 100 klb

Cable diameter: 7.6 mm

The shield is floating

(On request the shield can be connected to the load cell body)

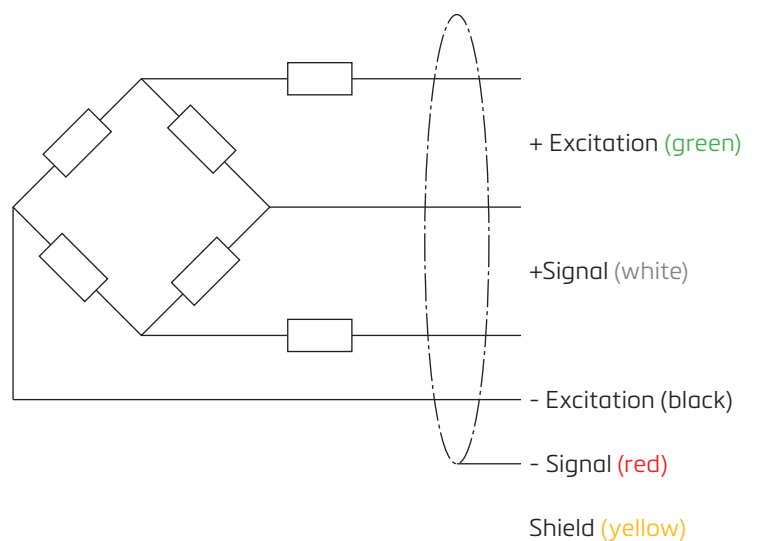

Specifications and dimensions are subject to change without notice.