

---

# PC22 single point load cell

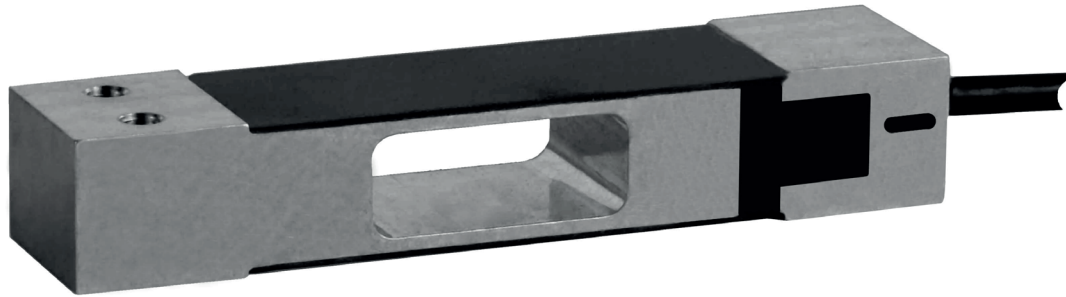

## product description

The PC22 is a compact, low capacity aluminium single point load cell ideal for a wide range of weighing applications. Environmentally sealed with potting compound to ensure durability. The industry standard size and mounting hole configuration makes the PC22 ideal for new equipment manufacturer or as a replacement fitting.

## applications

Retail scales, bench scales, small platform scales, multi-head weighers, medical scales.

## key features

Aluminium construction

---

Environmentally sealed by potting to IP67

---

Low profile design

---

For platform sizes of up to 350 x 350mm

---

Capacities from 5kg to 40kg

---

## approvals

OIML approval to C3 (Y = 6,000)

---

ATEX hazardous area approval for zones 0, 1, 2, 20, 21 and 22

---

FM hazardous area approval

---

## accessories

Compatible range of electronics

---

## options

Y = 12,000 for C3

---



RoHS  
compliant



## specifications

Maximum capacity ( $E_{max}$ )	kg	5 / 10 / 20 / 30 / 40	
Accuracy class according to OIML R60		(GP)	C3
Maximum number of verification intervals ( $n_{LC}$ )		n.a.	3,000
Minimum load cell verification interval ( $v_{min}$ )		n.a.	$E_{max} / 6,000$
Temperature effect on minimum dead load output ( $TC_0$ )	%*RO/10°C	± 0.0400	± 0.0233
Temperature effect on sensitivity ( $TC_{RO}$ )	%*RO/10°C	± 0.0200	± 0.0100
Combined error	%*RO	± 0.0500	± 0.0200
Non-linearity	%*RO	± 0.0400	± 0.0166
Hysteresis	%*RO	± 0.0400	± 0.0166
Creep error (30 minutes) / DR	%*RO	± 0.0600	± 0.0166
Optional: Min. load cell verification interval ( $v_{min opt}$ )		n.a.	$E_{max} / 12,000$
Optional: Temp. effect on min. dead load output ( $TC_0 opt$ )	%*RO/10°C	n.a.	± 0.0117
Rated Output (RO)	mV/V	2 ± 10%	
Zero balance	%*RO	± 5	
Excitation voltage	V	5...15	
Input resistance ( $R_{LC}$ )	Ω	413 ± 20	
Output resistance ( $R_{out}$ )	Ω	350 ± 25	
Insulation resistance (100 V DC)	MΩ	≥ 5,000	
Safe load limit ( $E_{lim}$ )	%* $E_{max}$	150	
Ultimate load	%* $E_{max}$	300	
Safe side load	%* $E_{max}$	100	
Maximum platform size; loading acc. to OIML R76	mm	350 x 350	
Maximum off centre distance at maximum capacity	mm	115	
Compensated temperature range	°C	-10...+40	
Operating temperature range	°C	-20...+65 (ATEX -20...+60)	
Load cell material		aluminium	
Sealing		potted	
Protection according EN 60 529		IP67	
Packet weight	kg	0.35	

The limits for Non-Linearity, Hysteresis, and  $TC_{RO}$  are typical values.

The sum of Non-linearity, Hysteresis and  $TC_{RO}$  meets the requirements according to OIML R60 with  $p_{LC}=0.7$ .



## product dimensions (mm)

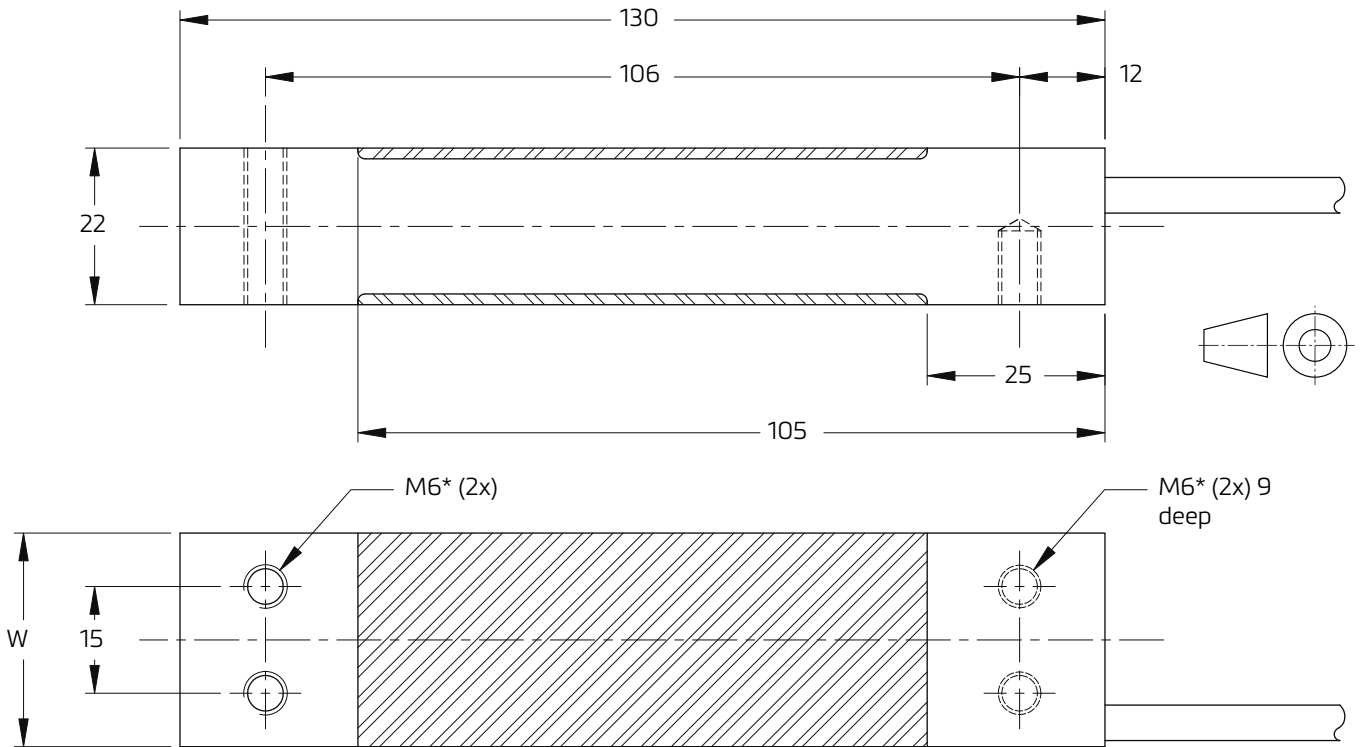

Capacity (kg)	W	
5, 10	25.4	+0.2
		-1.0
20, 30, 40	30	0.2
		-1

Mounting bolts M6 8.8; torque 10 Nm. Torque value assumes oiled threads.  
 \* Unified thread 1/4-20 UNC is available.

## wiring

The load cell is provided with a shielded, 6 conductor cable (AWG 26).

Cable jacket: polyurethane

Cable length: 2 m

Cable diameter: 5 mm

The shield is connected to the load cell body

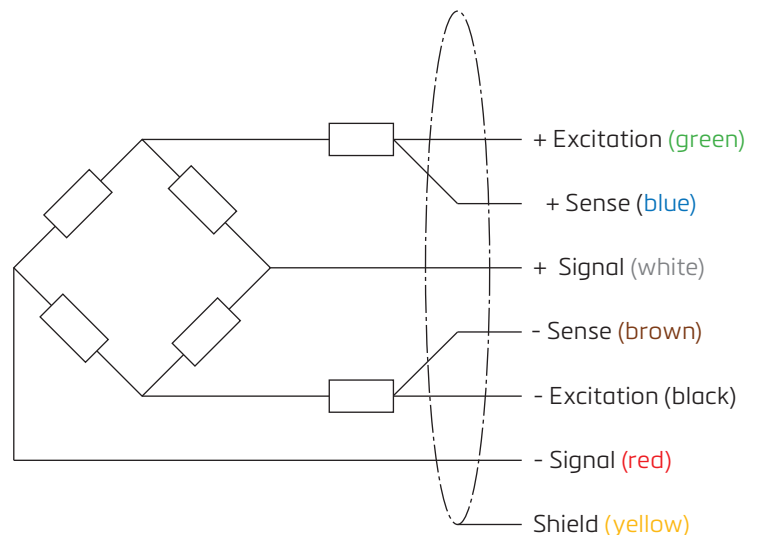

Specifications and dimensions are subject to change without notice.