

SR23



HIGH EFFICIENCY FORK SENSOR FOR BOOKLET AND MULTILAYER LABELS DETECTION

- Multilayer labels detection
- Up to 0,5 mm of minimum size labels/gap
- 5 mm slot width
- 50 mm slot depth
- Dynamic or static setting through single push-button
- 12 kHz switching frequency
- Compact and robust housing, IP65
- M8 connector or 2 m cable models
- PNP or NPN models



APPLICATIONS

- Processing and Packaging machinery
- Automatic labelers

SR23

Slot width		5 mm
Slot depth		50 mm
Switching frequency		12 kHz
Light emission		IR LED
Setting		push button
Power supply	Vdc	10...30 Vdc
	Vac	
	Vac/dc	
Output	PNP	•
	NPN	•
	NPN/PNP	
	relay	
	other	
Connection	cable	•
	connector	•
	pig-tail	
Approximate dimensions (mm)		30x63x10
Housing material		Alluminum (Zama), Plastic (PBT)
Mechanical protection		IP65

TECHNICAL DATA

Power supply	10 ... 30 Vdc (reverse polarity protection)
Ripple	2 Vpp max.
Consumption (output current excluded)	30 mA max.
Light emission	IR LED 850 nm
Setting	SET push-button
Indicators	yellow OUTPUT LED green READY LED
Output	PNP or NPN
Output current	100 mA max.
Saturation voltage	2 V max.
Slot width	5 mm
Slot depth	50 mm
Minimum label width	0,5...2 mm
Minimum space between labels	0,5...2 mm
Speed of the conveyor during setting procedure	20 m/min (30 cm/s) max.
Response time	40 µs max.
Switching frequency	12 kHz max.
Connection	M8 4-pole connector, 2 m cable
Dielectric strength	500 Vac, 1 min between electronics and housing
Insulating resistance	> 20 MΩ, 500 Vdc between electronics and housing
Mechanical protection	IP65
Ambient light rejection	according to EN 60947-5-2
Vibrations	0,5 mm amplitude, 10 ... 55 Hz frequency, for every axis (EN60068-2-6)
Shock resistance	11 ms (30 G) 6 shock for every axis (EN60068-2-27)
Housing material	Aluminum (Zama)
Cover material	PBT
Lens material	PC
Operating temperature	-20 ... 55°C
Storage temperature	-20 ... 70°C
Weight	85 g cable vers., 46 g M8 conn. vers.

DIMENSIONS

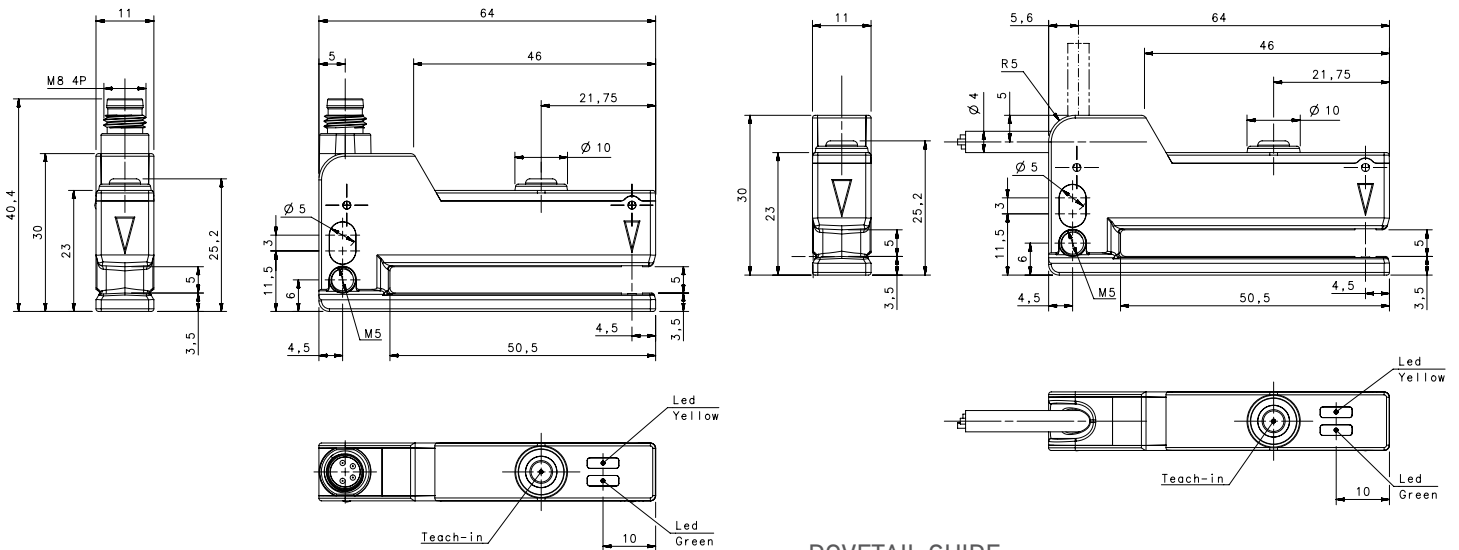

DOVETAIL GUIDE MOUNTING

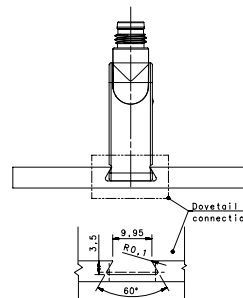

INDICATORS AND SETTINGS

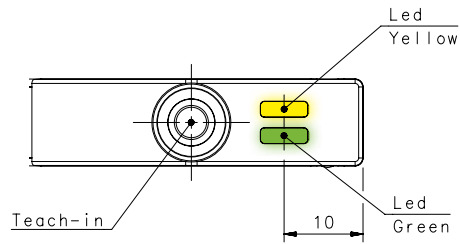

CONNECTIONS

M8 CONNECTOR



CABLE

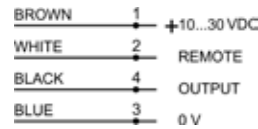

MODEL SELECTION AND ORDER INFORMATION

OPTIC FUNCTION	CONNECTION	OUTPUT	MODEL	ORDER No.
Fork Sensor	2m Cable	PNP	SR23-2-IR-PH	953161000
		NPN	SR23-2-IR-NH	953161020
	M8 Connector	PNP	SR23-5-IR-PH	953161010
		NPN	SR23-5-IR-NH	953161030

CABLES

TYPE	DESCRIPTION	LENGTH	MODEL	ORDER No.
Axial M8 Connector	4-pole, grey, P.V.C.	3 m	CS-B1-02-G-03	95A251420
		5 m	CS-B1-02-G-05	95A251430
		7 m	CS-B1-02-G-07	95A251440
		10 m	CS-B1-02-G-10	95A251480
	4-pole, P.U.R.	2 m	CS-B1-02-R-02	95A251620
		5 m	CS-B1-02-R-05	95A251640
Radial M8 Connector	4-pole, grey, P.V.C.	3 m	CS-B2-02-G-03	95A251450
		5 m	CS-B2-02-G-05	95A251460
		7 m	CS-B2-02-G-07	95A251470
		10 m	CS-B2-02-G-10	95A251530
	4-pole, P.U.R.	2 m	CS-B2-02-R-02	95A251630
		5 m	CS-B2-02-R-05	95A251650

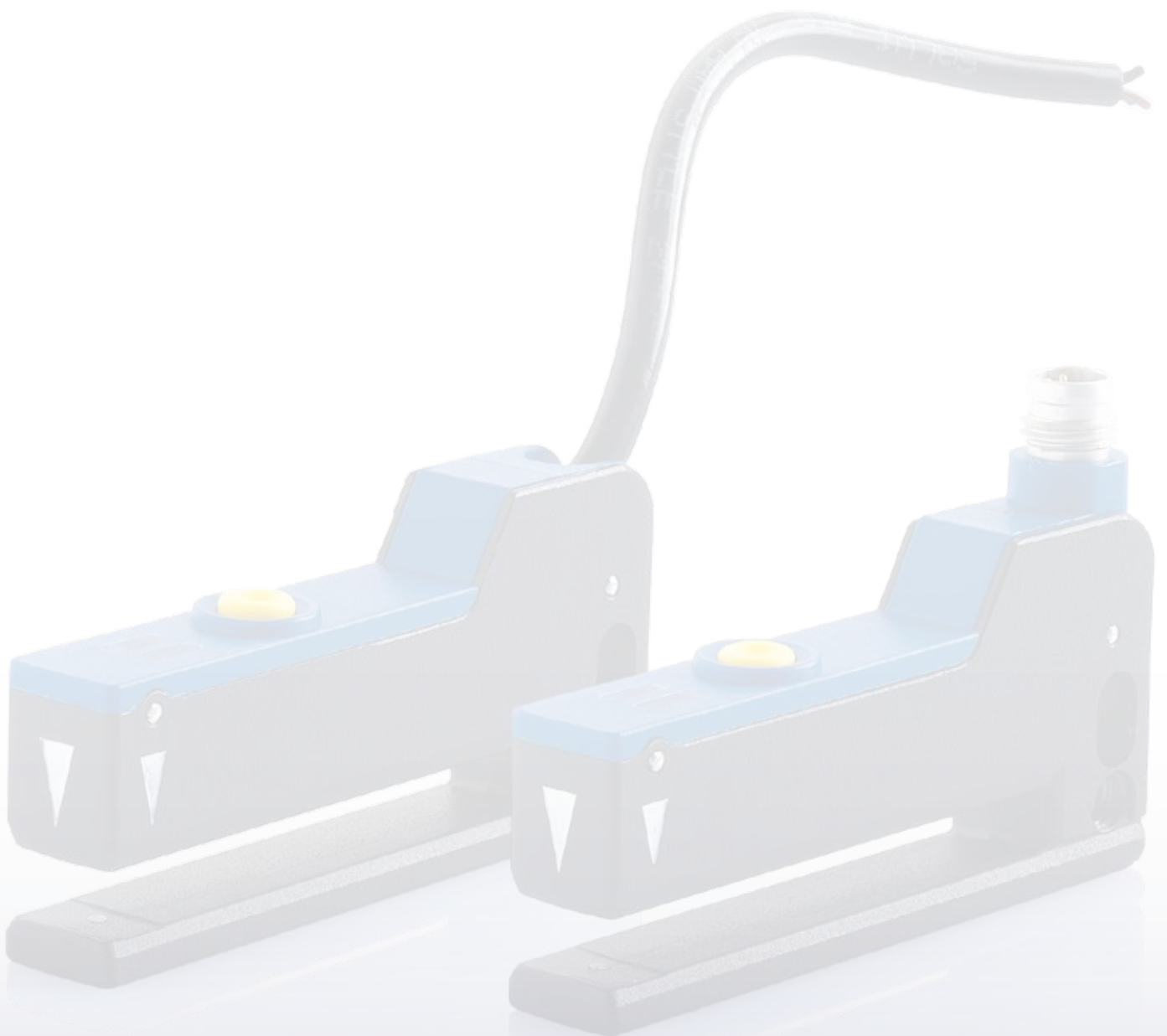

Rev. 03, 04/2019