



A30

Hardware Guide

Publication # 843-0153 (Rev F)

Datalogic S.r.l. Via S. Vitalino 13
40012 Calderara di Reno – Italy
<http://www.datalogic.com>
mvsupport@datalogic.com

A30™ Hardware Guide

Edited: 09/2017

© 2015 - 2017 • Datalogic S.p.A. and/or its affiliates • All rights reserved. • Without limiting the rights under copyright, no part of this documentation may be reproduced, stored in or introduced into a retrieval system, or transmitted in any form or by any means, or for any purpose, without the express written permission of Datalogic S.p.A. and/or its affiliates. • Datalogic and the Datalogic logo are registered trademarks of Datalogic S.p.A. in many countries, including the U.S. and the E.U. □ Impact, P-Series, Vision Program Manager (VPM), Pinpoint Pattern Find, and Control Panel Manager (CPM) are trademarks of Datalogic S.p.A. and/or its affiliates, registered in many countries, including the U.S. and the E.U. □ All other trademarks and brands are property of their respective owners.

Printed 11 September 2017

TABLE OF CONTENTS

REFERENCES	iii
Conventions	iii
Reference Documentation	iii
Support Through The Website	iii
Patents	iii
COMPLIANCE	iii
EAC COMPLIANCE	iii
Power Supply.....	iv
CE Compliance	iv
Warning	iv
HANDLING	iv
GENERAL VIEW	vii
1 RAPID CONFIGURATION	1
Step 1 – Assemble the Camera	1
Step 2 – Connect the System	2
Step 3 – Mount and Position the Camera.....	4
Step 4 – Focus the Camera	4
Step 5 – Calibrate Image Density.....	4
2 INTRODUCTION	5
2.1 Product Description.....	5
2.2 Indicators and Keypad Button	6
2.3 Accessories	7
3 INSTALLATION	8
3.1 Package Contents.....	8
3.2 Mechanical Dimensions	9
3.3 Mounting and Positioning the camera	11
4 CBX ELECTRICAL CONNECTIONS	13
4.1 Power Supply.....	14
4.1.1 Recommended Power Supplies	14
4.2 RS232 Serial Interface.....	15
4.2.1 RS485 Full-Duplex Interface	15
4.3 Auxiliary RS232 Serial Interface.....	15
4.4 Inputs.....	16
4.5 Outputs	21
4.6 External Illuminators	23
5 CAMERA ELECTRICAL CONNECTIONS	24
5.1 Power, Serial, and I/O terminal block	24
5.2 Power, Serial, and I/O cable	25
5.3 GigaEthernet Connector	27
5.4 Power Supply.....	27

TABLE OF CONTENTS

5.4.1	Recommended Power Supplies	28
5.5	RS232 Serial Interface	28
5.5.1	RS485 Full-Duplex Interface	29
5.5.2	Auxiliary RS232 Serial Interface	29
5.6	Ethernet Interface	29
5.7	Inputs	31
5.8	Outputs	35
6	TYPICAL LAYOUTS	38
6.1	Embedded (On-Board) GigaEthernet	38
6.2	Ethernet Networks	39
6.2.1	External Trigger Ethernet Host	39
6.2.2	Software Trigger Ethernet Host	40
7	IMAGE CAPTURE FEATURES	41
7.1	Maximum Line Speed and Exposure Time Calculations	41
8	SOFTWARE CONFIGURATION	43
8.1	VPM™ System Requirements	43
8.2	Installing Impact Software	43
8.3	Startup	44
8.3.1	Calibration	44
8.3.2	Partial Scan	45
9	MAINTENANCE	47
9.1	Cleaning	47
10	TROUBLESHOOTING	48
10.1	General Guidelines	48
11	TECHNICAL FEATURES	50
	GLOSSARY	51
	INDEX	54

REFERENCES

CONVENTIONS

This manual uses the following conventions:

"User" refers to anyone using an A30 camera.

"Camera" refers to an A30 camera.

"You" refers to the System Administrator or Technical Support person using this manual to install, configure, operate, maintain, or troubleshoot an A30 camera.

REFERENCE DOCUMENTATION

For further details refer to the Impact Reference Guide provided as supplementary documentation.

SUPPORT THROUGH THE WEBSITE

Datalogic provides several services as well as technical support through its website. Log on to www.datalogic.com and click on the [SUPPORT](#) > [Machine Vision](#) category link. From this page you can select your product model from the dropdown list which gives you access to:

- Downloads including Data Sheets, Manuals, Software & Utilities, and Drawings;
- Repair Program for On-Line Return Material Authorizations (RMAs) plus Repair Center contact information;
- Service Program containing details about Maintenance Agreements;
- Technical Support through email or phone.

PATENTS

This product is covered by one or more of the following patents:

U.S. patents: 6,512,218 B1; 6,616,039 B1; 6,808,114 B1; 6,997,385 B2; 7,102,116 B2; 7,282,688 B2

European patents: 999,514 B1; 1,014,292 B1; 1,128,315 B1.

Additional patents pending.

COMPLIANCE

For installation, use, and maintenance, it is not necessary to open the camera. Opening the camera will void the warranty.

Connect Ethernet and dataport connections to a network which has routing only within the plant or building and no routing outside the plant or building.

EAC COMPLIANCE

Customs Union:

The CU Conformity certification has been achieved; this allows the Product to bear the Eurasian mark of conformity.

POWER SUPPLY

ATTENTION: READ THIS INFORMATION BEFORE INSTALLING THE PRODUCT

This product is intended to be installed by Qualified Personnel only.

This product is intended to be connected to a UL Listed Direct Plug-in Power Unit marked LPS or “Class 2”, rated 10-30Vdc 1-0.33A.

CE COMPLIANCE

CE marking states the compliance of the product with essential requirements listed in the applicable European directive. Since the directives and applicable standards are subject to continuous updates, and since Datalogic promptly adopts these updates, therefore the EU declaration of conformity is a living document. The EU declaration of conformity is available for competent authorities and customers through Datalogic commercial reference contacts. Since April 20th, 2016 the main European directives applicable to Datalogic products require inclusion of an adequate analysis and assessment of the risk(s). This evaluation was carried out in relation to the applicable points of the standards listed in the Declaration of Conformity. Datalogic S.r.l. products are mainly designed for integration purposes into more complex systems. For this reason it is under the responsibility of the system integrator to do a new risk assessment regarding the final installation.

WARNING

This is a Class A product. In a domestic environment this product may cause radio interference in which case the user may be required to take adequate measures.

HANDLING

The A30™ camera is designed to be used in an industrial environment and is built to withstand vibration and shock when correctly installed. However, it is also a precision product and therefore it must be handled correctly before and during installation to avoid damage.

- Avoid dropping the camera (exceeding shock limits).

NO



- Do not fine tune the positioning by striking the camera or bracket.

NO

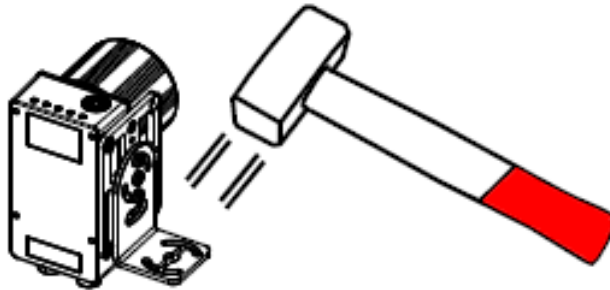

- Do not weld the camera into position. This can cause electrostatic, heat, or imager damage.



- Do not spray paint near the camera. This can cause imager damage.



GENERAL VIEW

A30™ Camera

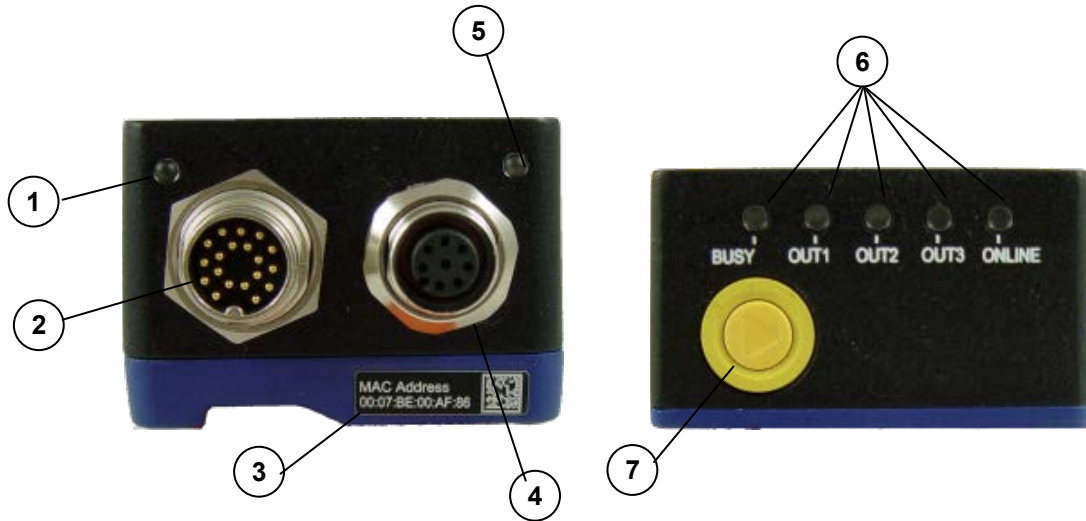

1	Power Indicator LED
2	Power, Serial Interface, and I/O Connector
3	MAC Address label
4	Ethernet Connector
5	Ethernet Network Presence LED
6	Indicator Lights (see page 6)
7	Reset and Camera Button Event (see page 6)

1 RAPID CONFIGURATION

STEP 1 – ASSEMBLE THE CAMERA

The first step to perform is to assemble any accessories that make up the A30™ camera. A lens must be used. A strobe or other external illuminator may be required.



The camera must be disconnected from the power supply during this procedure.

1. In a dust-free environment, remove the Camera Lens Cover by unscrewing it.



Do not touch the sensor aperture, lens glass or lens cover glass. These areas must be kept clean. Avoid any abrasive substances that might damage these surfaces during cleaning.

2. Remove the sensor protection label (dust cap) by pulling it off of the base.
3. Mount a lens by slowly screwing it onto the base until it arrives at the mechanical stop.

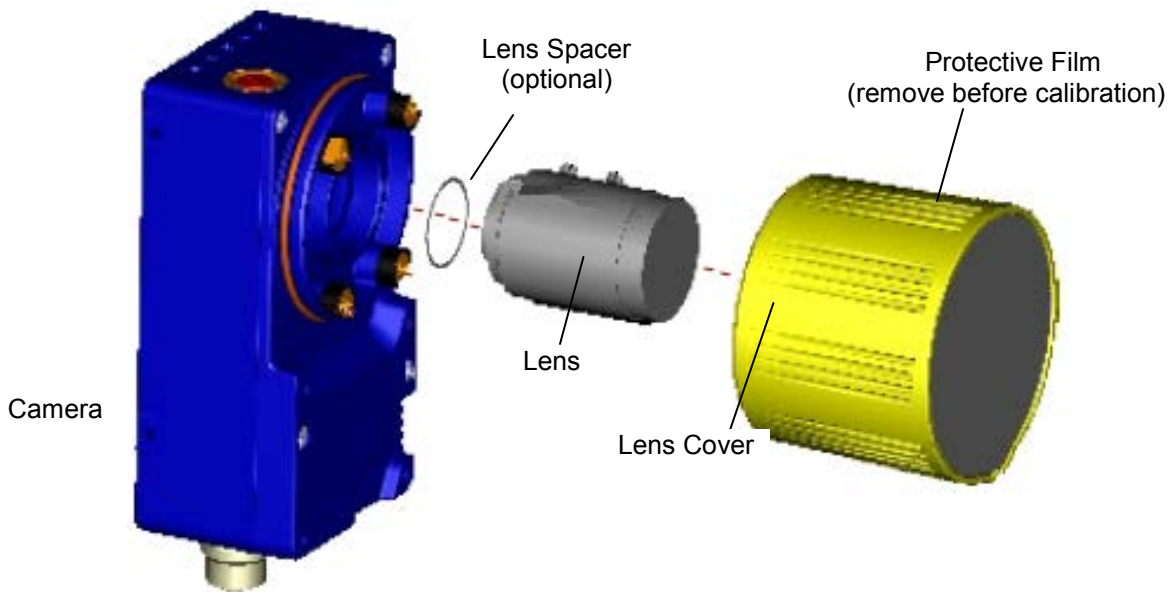

Figure 1 – Assembling the Camera and Lens

4. To keep dust and dirt off of the lens during mounting, temporarily replace the lens cover.

STEP 2 – CONNECT THE SYSTEM

In the typical standalone layout shown in the figure below, an Ethernet host is connected to the camera. The camera can use an external trigger to signal image acquisition.

The CBX is used to facilitate the connection between the camera and the host interface, external trigger, and optional input and output devices.

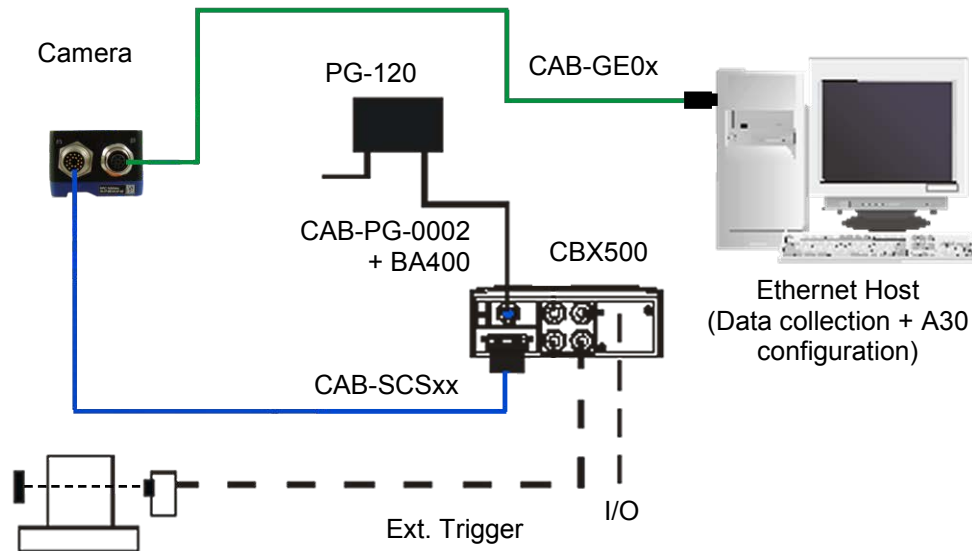

A30™ Standalone Layout to Ethernet Host

- **Power Supply Connection**

Use the PG-120 power Kit (3 versions for European, UK or US plug) and CAB-PG-0002 + BA400 connector to connect the PG-120 to the CBX. An alternative power supply to the PG-120 is the PWR-120.

- **CBX Connection**

Use CAB-SCSxx between the A30 camera and the CBX for power, external trigger device (photocell), and additional I/O connections.

Use the CAB-GE0x for the Gigabit Ethernet connection to the host.



NOTE

The A30 does not support sourcing power towards the CBX in order to power I/O devices. These devices must be powered through the CBX or from an external source.

CBX500 Connectors for A30™

The table below gives the CBX500 terminal block connectors. Use this table when the camera is connected using the CBX500.

CBX500 Terminal Block Connectors			
Input Power		Outputs	
Vdc	Power Supply Input Voltage +	+V	Power Source - Outputs
GND	Power Supply Input Voltage -	-V	Power Reference - Outputs
Earth	Protection Earth Ground	O1+	Output 1 +
		O1-	Output 1 -
Inputs		O2+	Output 2 +
+V	Power Source – External Trigger	O2-	Output 2 -
I1A	External Trigger + or - (polarity insensitive)	O3A	Strobe + / Output 3 + (See Note)
I1B	External Trigger + or - (polarity insensitive)	O3B	Strobe - / Output 3 -
-V	Power Reference – External Trigger	RS232 Interface	
+V	Power Source – Inputs	TX	Transmit
I2A	Input 2 + or - (polarity insensitive)	RX	Receive
I2B	Input 2 + or - (polarity insensitive)	SGND	Signal Ground
I3A	NOT USED		
I4A	NOT USED		
I34B	NOT USED		
-V	Power Reference – Inputs		
Shield			
Shield	Network Cable Shield		

Note: The strobe signal connection is shared with Output 3. If a non-zero value is defined for the Strobe Pulse Length value (in VPM – Impact – General), the strobe is active. If the value is zero, Output 3 is active.

 CAUTION	<p><i>Do not connect GND and SGND to different (external) ground references. GND and SGND are internally connected through filtering circuitry which can be permanently damaged if subjected to voltage drops over 0.8 Vdc.</i></p>
---	---

STEP 3 – MOUNT AND POSITION THE CAMERA

1. Mounting solutions are provided in Chapter 0 of this Hardware Guide.

STEP 4 – FOCUS THE CAMERA

1. Remove the lens cover.
2. Attach the correct accessory lens for your application.
3. Replace the lens cover, if needed.
4. Power the camera on. On the connector side of the camera near the cable, the “POWER ON” LED (blue) indicates the camera is correctly powered.
5. Start Impact Vision Program Manager (VPM) and use it to connect to the camera.
6. Direct the camera toward a correctly lighted calibration image or other clearly defined object.
7. Select the Settings tab, then click the Camera system object.
8. In the Camera Setup tab, click the Live button.
9. Adjust the lens until the image is clearly in focus in the VPM image window.

STEP 5 – CALIBRATE IMAGE DENSITY

In order to function correctly when inspecting images, the camera needs the image resolution or PPI (pixels per inch). This calibration procedure is necessary for first time installation, if the lens type is changed, or if the focal distance is changed.

There are several methods available for calibrating the camera. Refer to the Calibration Panel section of the Impact Reference Guide (Publication # 843-0093) for complete details.

2 INTRODUCTION

2.1 PRODUCT DESCRIPTION

The A30 features a 1.1 GHz processor, 256 megabytes of flash memory, integrated Gigabit Ethernet, and a right-angle mount.

It provides a 640 x 480 pixel image at 60 frames per second using a 1/3" CCD imager.

Excellent Performance

- Adjustable focus through C-Mount lenses
- Frame Rate up to 60 frames/sec
- Partial Scan capabilities for higher frame rate

Flexible Solution

- Modular design
- Adjustable C-Mount lenses
- Complete set of Accessories like external lighting systems, mounting brackets, connection boxes, cables, and photocells
- Ethernet Connectivity to the host processor PC for parameter configuration, inspection program development, and data and image transfer.
- General purpose optocoupled I/Os

Industrial Strength

- Industrial compact camera
- Rugged full metal construction
- Sealed circular connectors
- IP65 protection class
- 45 °C (113 °F) max operating temperature
- Supply voltage ranges from 10 to 30 Vdc

2.2 INDICATORS AND KEYPAD BUTTON

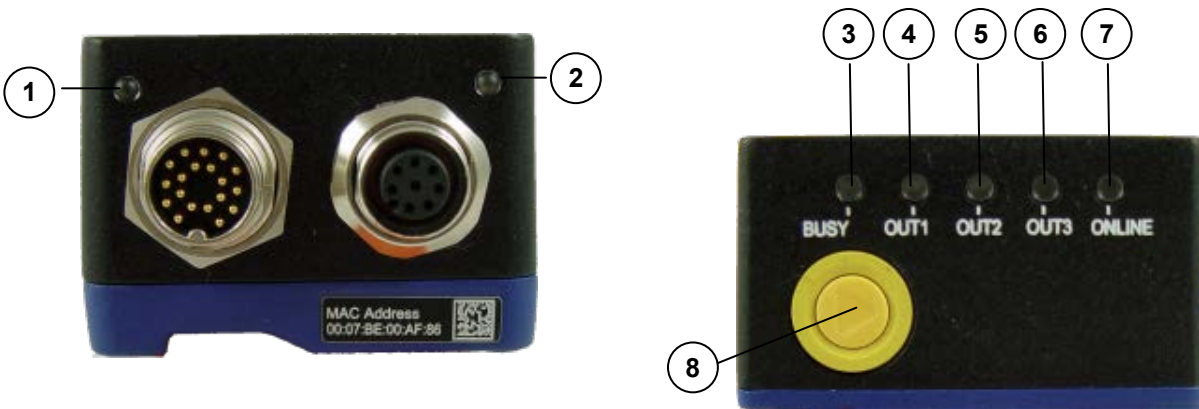

Figure 2 - Indicators

The following LED indicators are located on the camera (Figure 2):

1	POWER	On – camera is connected to power
2	NET	On – Ethernet link is established. Blinking - data transmission
3	BUSY	LED blinks during image and flash memory access
4	OUT1	On – Output 1 is on
5	OUT2	On – Output 2 is on
6	OUT3	On – Output 3 is on
7	ONLINE	On – Loaded tasks will be executed based on their trigger parameters
8	BUTTON	Camera Reset: See Note below Camera Button event: Press and release the button (Internal software event trigger only)

Note: Camera Reset restores the factory camera settings including deleting all user settings and resetting the camera's Mask and IP Address to the factory default (192.168.0.128).

To Reset the Camera

1. Turn off camera power.
2. Press and hold the Camera Reset button.
3. Turn on power. Continue holding the Camera Reset button.
4. After about 30 seconds, all the LED indicators turn on for a few seconds. Continue holding the Camera Reset button.
5. The LED indicators turn off for about five seconds, then turn on.
6. When all the LED indicators have turned on and remain lit, release the Camera Reset button.
7. Wait approximately 30 seconds for the camera to restart.

2.3 ACCESSORIES

The following is a partial list of optional accessories for the A30 camera.

Model	Description	Order No.
OCR Software License	OCR Software License	098-0223
CAB-SCS01 Cable, A30/T4x to CBX, 1M	A30 to CBX connection cable - 1 meter	95A906068
CAB-SCS03 Cable, A30/T4x to CBX, 3M	A30 to CBX connection cable - 3 meters	95A906069
CAB-SCS05 Cable, A30/T4x to CBX, 5M	A30 to CBX connection cable - 5 meters	95A906070
CAB-SCS10 Cable, A30/T4x to CBX, 10M	A30 to CBX connection cable - 10 meters	95A906071
CAB-GE01 M12-IP67 TO RJ45 1M	Gig-E Ethernet cable - 1 meter	93A050034
CAB-GE03 M12-IP67 TO RJ45 3M	Gig-E Ethernet cable - 3 meter	93A050035
CAB-GE05 M12-IP67 TO RJ45 5M	Gig-E Ethernet cable - 5 meter	93A050036
CAB-GE10 M12-IP67 TO RJ45 10M	Gig-E Ethernet cable - 10 meter	93A051389
I/O Board, A30/T4x, Female DB25, DIN Rail Mountable	I/O Board, DIN Rail Mountable	95A906346
CBX500 CONNECTION BOX MODULAR	CBX500 connection box	93A301068
CBX800 GATEWAY	CBX800 connection box	93A301077
BM300 PROFIBUS MODULE	Profibus module	93ACC1810
BM310 PROFIBUS IP65 MODULE	Profibus module with IP65 connector	93ACC1811
BA100 DIN RAIL ADAPTERS	CBX adapter for DIN rail mounting	93ACC1821
BA200 BOSCH ADAPTERS	CBX adapter for Bosch profile mounting	93ACC1822

3 INSTALLATION

3.1 PACKAGE CONTENTS

Verify that the A30™ camera and all the parts supplied with the equipment are present and intact when opening the packaging. The list of parts includes:

- ❑ A30 camera with Lens Cover
- ❑ Software and Documentation CD
- ❑ QuickStart Guide
- ❑ Mounting Kit
 - Mounting Screws (4 + 3)
 - Washers (2)
 - Mounting Brackets (2)

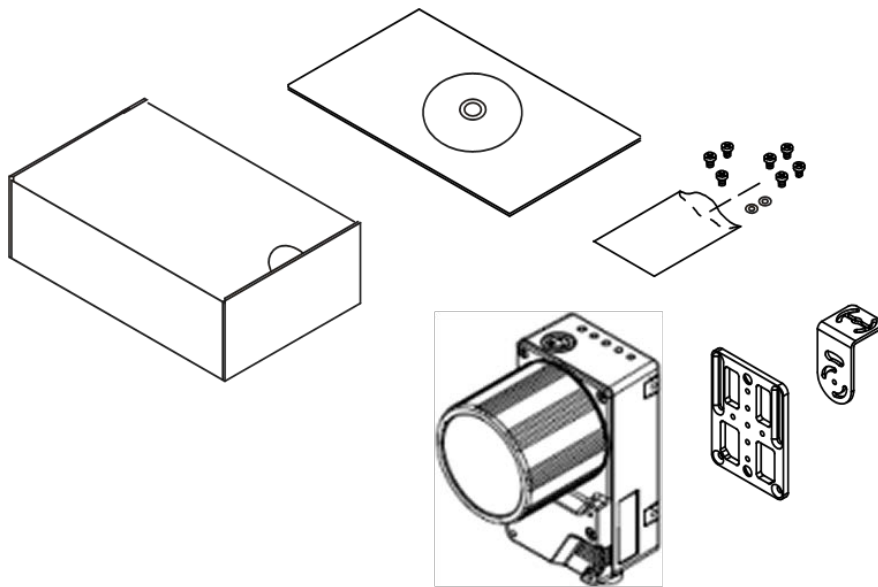

Figure 3 – A30 Package Contents

3.2 MECHANICAL DIMENSIONS

The A30 can be installed to operate in different positions using the body mounting bracket shown in Figure 5. The twelve screw holes (M4) on the body of the camera can be used for custom mounting solutions.

The diagram below gives the overall dimensions of the camera.

Refer to section 3.3 for various mounting solutions and correct positioning.

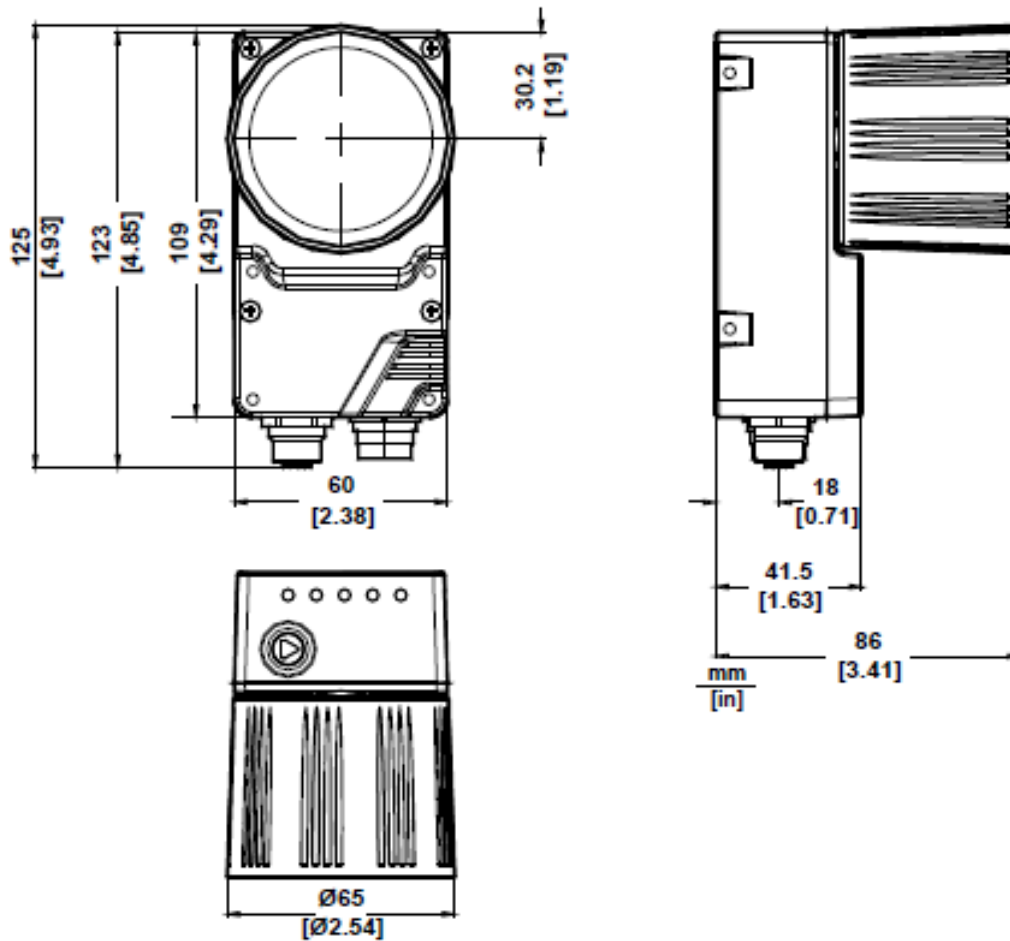

Figure 4 – A30 Overall Dimensions

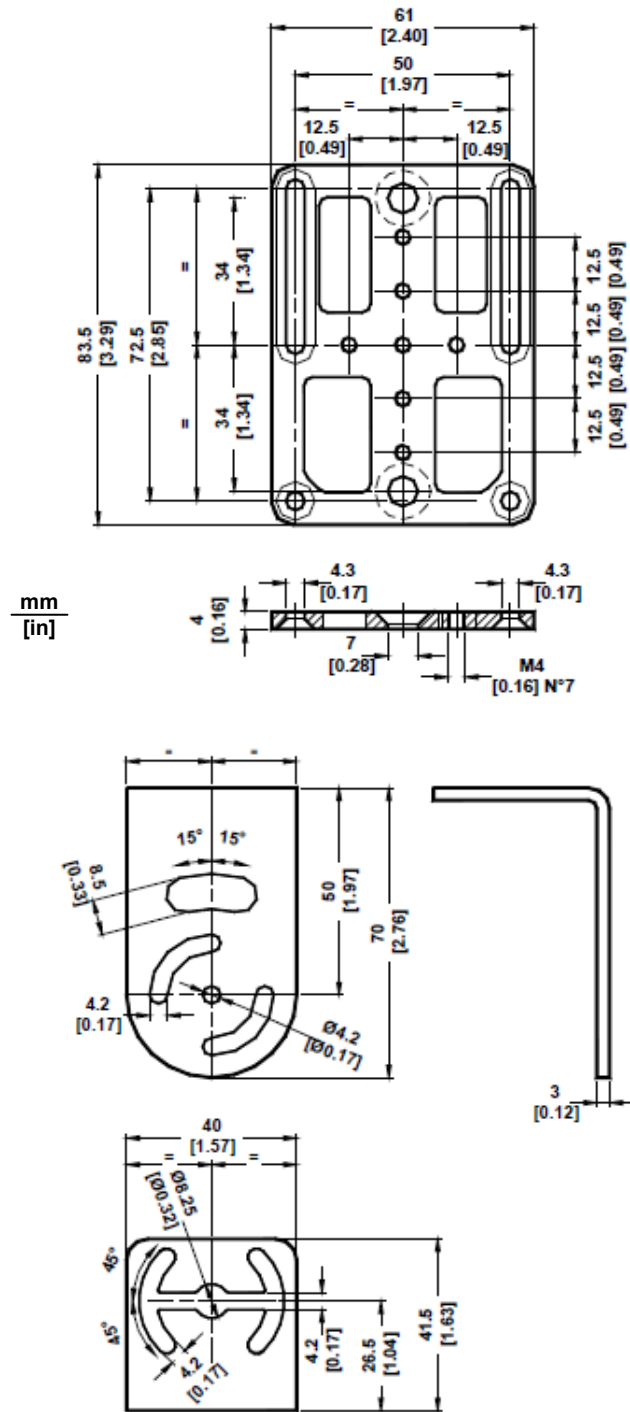

Figure 5 – Mounting Bracket Overall Dimensions

3.3 MOUNTING AND POSITIONING THE CAMERA

Using the A30 mounting brackets, you can obtain rotation on the various axes of the camera as shown in the diagrams below.

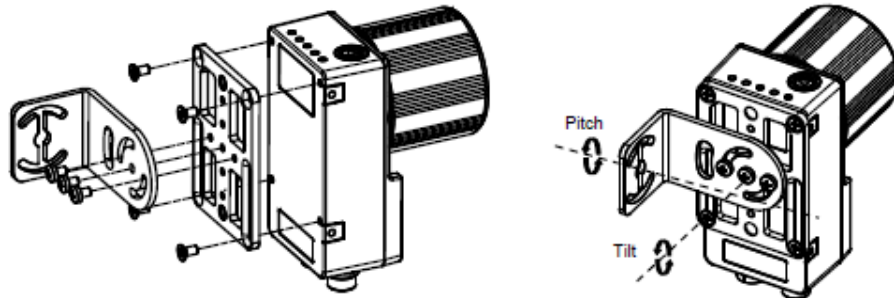

Figure 6 –Positioning with Body Mounting Bracket (Back)

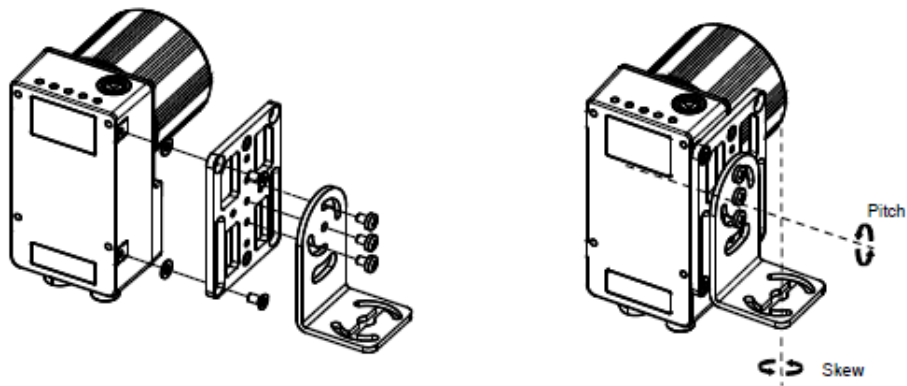

Figure 7 –Positioning with Body Mounting Bracket (Side)

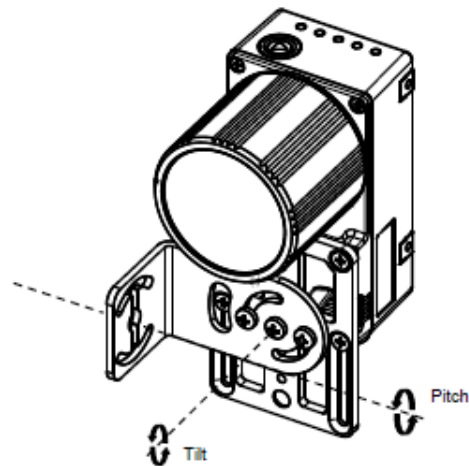

Figure 8 –Positioning with Body Mounting Bracket (Front)

The A30 camera is able to capture images at a variety of angles.

When mounting the camera, take into consideration that significant pitch, skew, or tilt may degrade accuracy.

The **Pitch** and **Skew** angles are represented by the values **P** and **S** in Figure 9 and Figure 10. Position the camera to avoid the direct reflection of the light emitted by the camera or other lighting. In some cases, such as low contrast or low illumination, the **Pitch** or **Skew** angle should be adjusted.

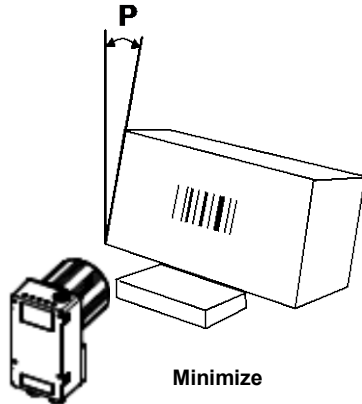

Figure 9 - Pitch angle

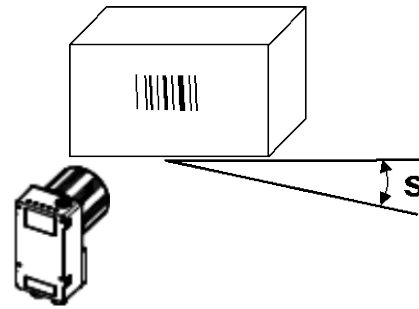

Figure 10 - Skew angle

The **Tilt** angle is represented by the value **T** in Figure 11.

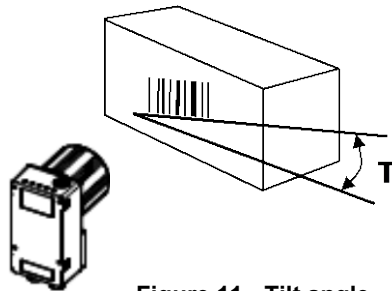

Figure 11 - Tilt angle

4 CBX ELECTRICAL CONNECTIONS

All A30 cameras can be connected to a CBX500 connection box using a **CAB-SCSxx** accessory cable. These accessory cables terminate in a 19-pin connector on the camera side and in a 25-pin male D-sub connector on the CBX side. (See Power, Serial, and I/O Connector on page 25.)

We recommend making system connections through one of the CBX connection boxes since they offer the advantages of easy connection, easy device replacement, and filtered reference signals.



NOTE

If you require direct or terminal block wiring to the camera, see Page 25.

The table below shows the terminal block connections for the CBX500.

CBX500 Terminal Block Connectors	
Input Power	
Vdc	Power Supply Input Voltage +
GND	Power Supply Input Voltage -
Earth	Protection Earth Ground
Inputs	
+V	Power Source – External Trigger
I1A	External Trigger + or - (polarity insensitive)
I1B	External Trigger + or - (polarity insensitive)
-V	Power Reference – External Trigger
+V	Power Source – Inputs
I2A	Input 2 + or - (polarity insensitive)
I2B	Input 2 + or - (polarity insensitive)
I3A	NOT USED
I4A	NOT USED
I34B	NOT USED
-V	Power Reference – Inputs
Outputs	
+V	Power Source - Outputs
-V	Power Reference - Outputs
O1+	Output 1 +
O1-	Output 1 -
O2+	Output 2 +
O2-	Output 2 -
O3A	Strobe + / Output 3 + (See Note)
O3B	Strobe - / Output 3 -
RS232 Interface	
TX	Transmit
RX	Receive
SGND	Signal Ground

Note: The strobe signal connection is shared with Output 3. If a non-zero value is defined for the Strobe Pulse Length value (in VPM – Impact – General), the strobe is active. If the value is zero, Output 3 is active.



CAUTION

Do not connect GND and SGND to different (external) ground references. GND and SGND are internally connected through filtering circuitry which can be permanently damaged if subjected to voltage drops over 0.8 Vdc.

**NOTE**

To avoid electromagnetic interference when the camera is connected to a CBX connection box, verify the jumper positions in the CBX as indicated in its Installation Manual.

4.1 POWER SUPPLY

**NOTE**

The A30 does not support sourcing power towards the CBX through the CBX "power from device" source jumper setting. Power must be supplied to the CBX as shown below.

To power the camera and/or I/O devices through the CBX, power must be supplied to the CBX500 spring clamp terminal pins as shown in Figure 12:

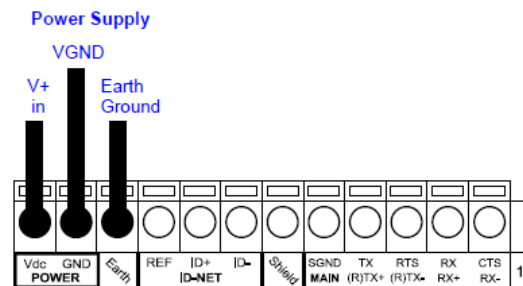

Figure 12 - Power Supply Connections

The power must be between 10 and 30 Vdc only.

It is recommended to connect the device CHASSIS to earth ground (Earth) by setting the appropriate jumper in the CBX connection box. See the CBX Installation Manual for details.

4.1.1 Recommended Power Supplies

The following optional accessory power supplies are recommended for A30 cameras:

Power Supplies	
Power Supply	Number of Cameras Supported
PG-120	2
PWR-120	2
PWR-240	4
PWR-480A	8

4.2 RS232 SERIAL INTERFACE

The signals relative to the following serial interface types are available on the CBX spring clamp terminal blocks.

The serial interface parameters (baud rate, data bits, etc.) are defined in Vision Program Manager (VPM) software. Refer to the Serial Port section of the Impact Reference Guide (Publication # 843-0093).

The following pins are used for RS232 interface connection. The Impact software does not support hardware (CTS/RTS) or software (Xon/Xoff) data flow control.

CBX500	Function
TX	Transmit Data
RX	Receive Data
SGND	Signal Ground

It is always advisable to use shielded cables. The overall maximum cable length must be less than 15 m (49.2 ft.).

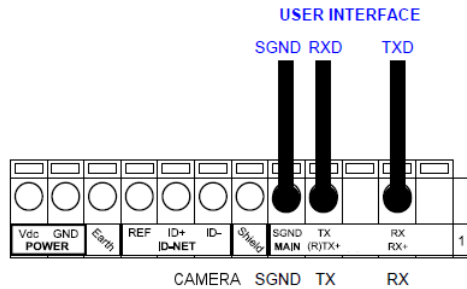



Figure 13 – RS232 Main Interface Connections Using Hardware Handshaking

4.2.1 RS485 Full-Duplex Interface

The Impact software does not support RS485 protocol.

4.3 AUXILIARY RS232 SERIAL INTERFACE

The 9-pin female Auxiliary Interface connector inside the CBX is to be used by Factory and Support personnel only.



Do not make any connections to the Aux Interface.

NOTE

4.4 INPUTS

There are two optocoupled polarity insensitive inputs available on the camera: Input 1 (Trigger) and Input 2, a generic input:

The Trigger is used to trigger the camera so that it will acquire an image.

Input 2 can be used as a signal to a software task to perform an action.

The electrical features of both inputs are:

$$V_{AB} = 30 \text{ Vdc max.}$$

$$I_{IN} = 10 \text{ mA (camera) + 12 mA (CBX) max.}$$

The active state of these inputs are selected in software. Refer to the Camera Setup tab and Discrete Input tool sections of the Impact Reference Guide (Publication # 843-0093).

An anti-disturbance filter is implemented in software on both inputs so that the minimum pulse duration is $\cong 0.5$ milliseconds. This value can be increased through the software parameter Debounce Filter. Refer to the Camera Setup tab section in the Impact Reference Guide for further details.

These inputs are optocoupled and can be driven by both NPN and PNP type commands.



NOTE

Polarity insensitive inputs assure full functionality even if pins A and B are exchanged.

The connections are indicated in the following diagrams:

EXTERNAL TRIGGER INPUT CONNECTIONS USING CBX POWER

CBX500	Function
+V	Power Source - External Trigger
I1A	External Trigger + or - (polarity insensitive)
I1B	External Trigger + or - (polarity insensitive)
-V	Power Reference - External Trigger



CAUTION *Power is available directly to the Input Device, independently from the Power Supply Switch inside the CBX.*

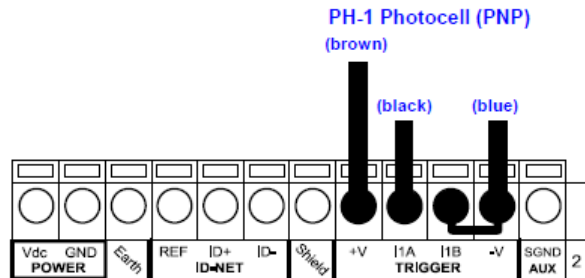

Figure 14 – PH-1 External Trigger Using CBX Power

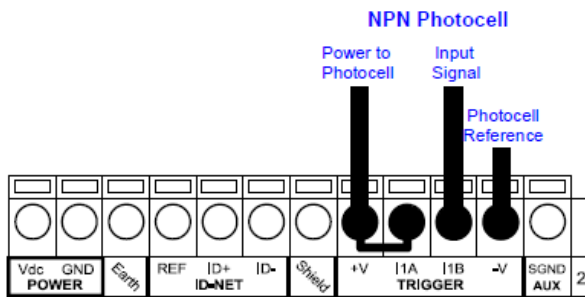

Figure 15 - NPN External Trigger Using CBX Power

EXTERNAL TRIGGER INPUT CONNECTIONS USING EXTERNAL POWER

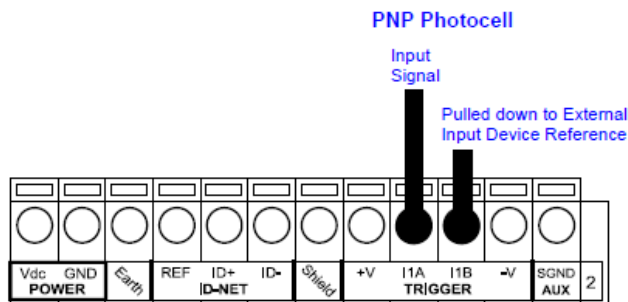

Figure 16 - PNP External Trigger Using External Power

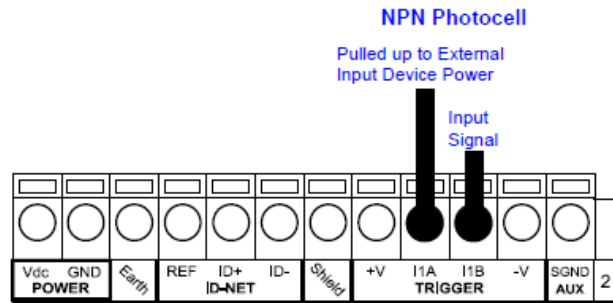



Figure 17 - NPN External Trigger Using External Power

INPUT 2 CONNECTIONS USING CBX POWER

CBX500	Function
+V	Power Source - Inputs
I2A	Input 2 + or - (polarity insensitive)
I2B	Input 2 + or - (polarity insensitive)
-V	Power Reference - Inputs



CAUTION *Power is available directly to the Input Device, independently from the Power Supply Switch inside the CBX.*

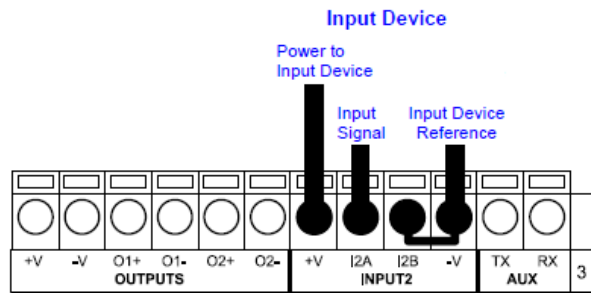

Figure 18 - PNP Input 2 Using CBX Power

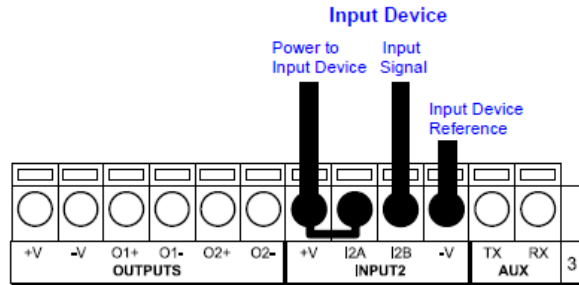

Figure 19 - NPN Input 2 Using CBX Power

INPUT 2 CONNECTIONS USING EXTERNAL POWER

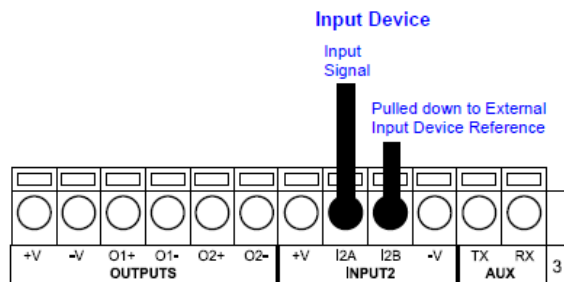

Figure 20 - PNP Input 2 Using External Power

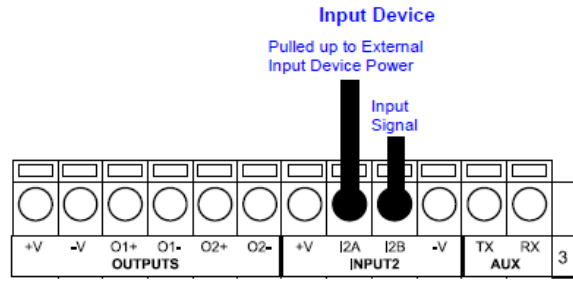

Figure 21 - NPN Input 2 Using External Power

4.5 OUTPUTS

Three optocoupled general purpose outputs are available. The meaning of the outputs can be defined by the user. They are typically used either to signal the data collection result or to control an external lighting system.

The electrical features of the two outputs are the following:

$$V_{CE} = 30 \text{ Vdc max.}$$

$$I_{CE} = 40 \text{ mA continuous max.; } 130 \text{ mA pulsed max.}$$

$$V_{CE \text{ saturation}} = 1 \text{ Vdc max. @ } 10 \text{ mA}$$

$$P_D = 80 \text{ mW Max. @ } 45 \text{ }^\circ\text{C ambient temp.}$$

The output signals are fully programmable. Refer to the Discrete Output tool section in the Impact Reference Guide for further details.

OUTPUT CONNECTIONS USING CBX POWER

CBX500	Function
+V	Power Source - Outputs
O1+	Output 1 +
O1-	Output 1 -
O2+	Output 2 +
O2-	Output 2 -
O3A	Strobe + / Output 3 + (See Note)
O3B	Strobe - / Output 3 -
-V	Power Reference Outputs

Note: The strobe signal connection is shared with Output 3. If a non-zero value is defined for the Strobe Pulse Length value (in VPM – Impact – General), the strobe is active. If the value is zero, Output 3 is active.



CAUTION *Power is available directly to the Output Device, independently from the Power Supply Switch inside the CBX.*

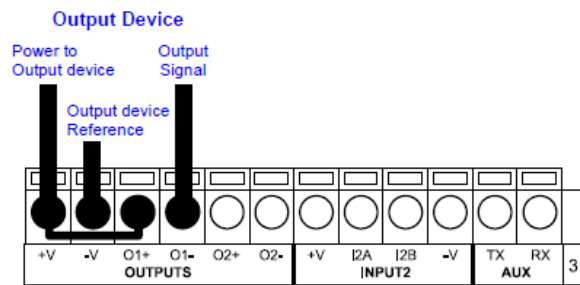

Figure 22 - Open Emitter Output Using CBX Power

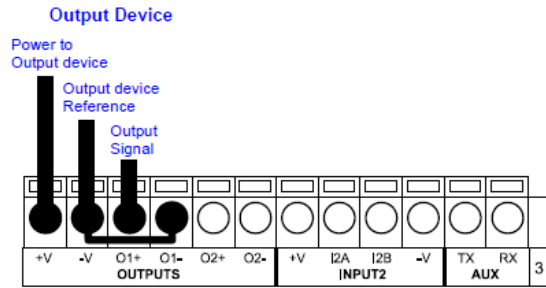

Figure 23 - Open Collector Output Using CBX Power

OUTPUT CONNECTIONS USING EXTERNAL POWER

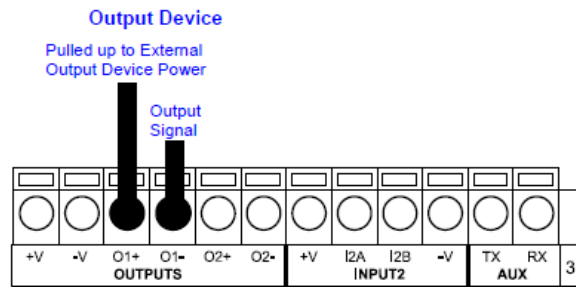

Figure 24 - Output Open Emitter Using External Power

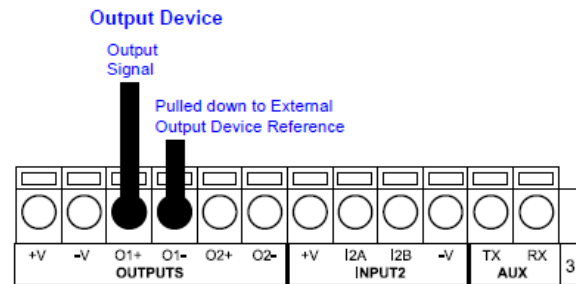



Figure 25 - Output Open Collector Using External Power

4.6 EXTERNAL ILLUMINATORS

If an External Illuminator (strobe light) is used, it can be powered from the CBX connection box. It must be connected to the **Vdc** and **GND** terminal clamps. The strobe signal connection is shared with Output 3. If a non-zero value is defined for the Strobe Pulse Length value (in VPM – Impact – General), the strobe is active. If the value is zero, Output 3 is active.



CAUTION *Power is available directly to the strobe, independently from the Power Supply Switch inside the CBX.*

Configure the Strobe Signal in the VPM software. Refer to the Camera Setup tab section of the Impact Reference Guide.

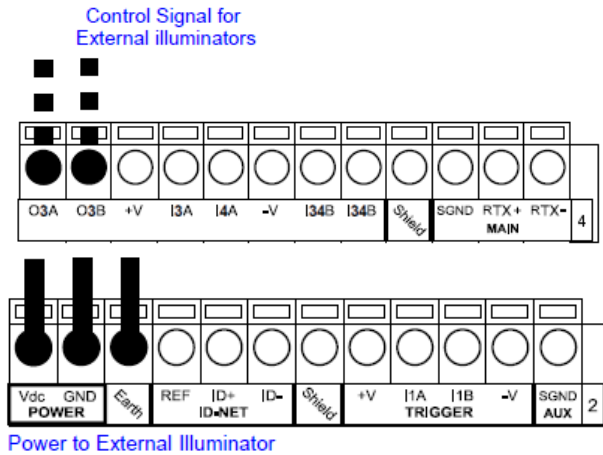

Figure 26 – External Illuminator Connections

Below is a table summarizing the External Illuminator wiring and power requirements.

CBX/Camera Signal	Meaning
Vdc	10 to 30 Vdc
GND	Ground
Earth	Shield/Earth Ground
O3B	Control Signal – (See Note)
O3A	Control Signal +

Note: The strobe signal connection is shared with Output 3. If a non-zero value is defined for the Strobe Pulse Length value (in VPM – Impact – General), the strobe is active. If the value is zero, Output 3 is active.

5 CAMERA ELECTRICAL CONNECTIONS

5.1 POWER, SERIAL, AND I/O TERMINAL BLOCK

Camera power, trigger signals, and strobe triggers can be connected to the camera using a terminal block and cable or an unterminated cable (see page 25). To use a terminal block (95A906346) you must also use the optional camera cable (CAB-SCSxx). **The camera cannot source power through this connector.**

Figure 27 – A30/T4x-Series I/O Block

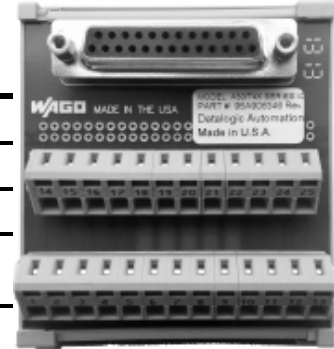

Terminal	Name	Function
9 & 13	Vdc	Power supply input voltage +
7 & 25	GND	Power supply input voltage -
18	I1A	External Trigger + or - (polarity insensitive)
19	I1B	External Trigger + or - (polarity insensitive)
6	I2A	Input 2 + or - (polarity insensitive)
10	I2B	Input 2 + or - (polarity insensitive)
22	O1-	Output 1 -
11	O2+	Output 2 +
8	O1+	Output 1 +
12	O2-	Output 2 -
2	TX	RS232 Transmit
3	RX	RS232 Receive
4	Not Used	Not Used
5	Not Used	Not Used
21	Not Used	Not Used
20	Not Used	Not Used
17	Strobe-/O3B	Strobe - / Output 3 – (See Note)
16	Strobe+/O3A	Strobe + / Output 3 +
1	CHASSIS	Cable shield internally connected by capacitor to the chassis in CBX500

Note: The strobe signal connection is shared with Output 3. If a non-zero value is defined for the Strobe Pulse Length value (in VPM – Impact – General), the strobe is active. If the value is zero, Output 3 is active.

5.2 POWER, SERIAL, AND I/O CABLE

The camera is equipped with an M16 19-pin male connector (Binder, 423 Series) for connection to the power supply, serial interface and input/output signals. The details of the 19-pin and 25-pin connectors are shown here for using an unterminated cable. **The camera cannot source power through this connector.**

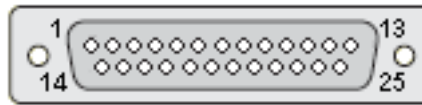
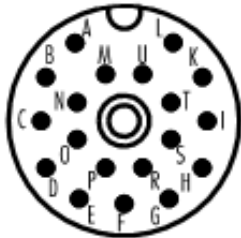

Figure 28 – M16 19-pin Connector (Pin Side)

25-pin D-Sub Connector (Pin Side)

Connector Pinout				
25-Pin	19-Pin	Wire Color	Name	Function
9 & 13	A	Red	Vdc	Power supply input voltage +
7 & 25	L	Black	GND	Power supply input voltage -
18	B	Orange	I1A	External Trigger + or - (polarity insensitive)
19	C	Green-Black	I1B	External Trigger + or - (polarity insensitive)
6	D	Grey	I2A	Input 2 + or - (polarity insensitive)
10	E	Green-Red	I2B	Input 2 + or - (polarity insensitive)
22	F	Black-White	O1-	Output 1 -
11	G	White-Red	O2+	Output 2 +
8	H	Purple	O1+	Output 1 +
12	I	White-Blue	O2-	Output 2 -
2	M	Yellow	TX	RS232 Transmit
3	U	Brown	RX	RS232 Receive
4	N	Pink		Not Used
5	T	Green		Not Used
21	O	Yellow-White		Not Used
20	S	Yellow-Blue		Not Used
17	R	White	Strobe-/O3B	Strobe - / Output 3 - (See Note)
16	P	Blue	Strobe+/O3A	Strobe + / Output 3 +
1	K	Shields	CHASSIS	Cable shield internally connected by capacitor to the chassis in CBX500

Note: The strobe signal connection is shared with Output 3. If a non-zero value is defined for the Strobe Pulse Length value (in VPM – Impact – General), the strobe is active. If the value is zero, Output 3 is active.

In order to meet EMC requirements:

- connect the camera chassis to the plant earth ground by means of a flat copper braid shorter than 100 mm
- connect the main interface cable shield to pin K of the 19-pin connector

**CAUTION**

Do not connect GND and SGND to different (external) ground references. GND and SGND are internally connected through filtering circuitry which can be permanently damaged if subjected to voltage drops over 0.8 Vdc.

5.3 GIGAETHERNET CONNECTOR

An M12 8-pin female connector is provided for the on-board GigaEthernet connection**. This interface is 1000BASE-T (also known as IEEE 802.3ab) compliant. See section 5.5 for connection details.

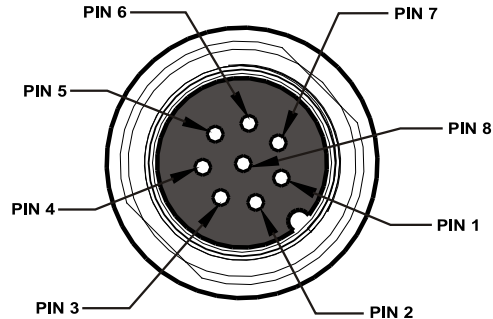

Figure 29 - M12 8-Pin Female GigaEthernet Network Connector

M12 8-Pin GigaEthernet Network Connector pinout		
Pin	Name	Function
1	DB-	Channel B bi-directional data (negative pin)
2	DD+	Channel D bi-directional data (positive pin)
3	DD-	Channel D bi-directional data (negative pin)
4	DA-	Channel A bi-directional data (negative pin)
5	DC+	Channel C bi-directional data (positive pin)
6	DA+	Channel A bi-directional data (positive pin)
7	DB+	Channel B bi-directional data (positive pin)
8	DC-	Channel C bi-directional data (negative pin)

(**) Due to the high speed signals, it is strongly suggested that you use CAT5e or CAT6 cables.

5.4 POWER SUPPLY

Power is supplied to the camera through the pins provided on the M16 19-pin connector (see Figure 29). **The camera cannot source power through this connector.**

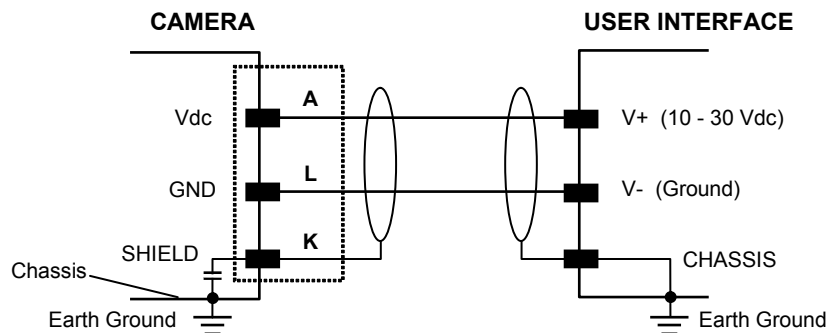

Figure 30 - Power Supply Connection

The allowed supply voltage range for the camera is 10 to 30 Vdc.

5.4.1 Recommended Power Supplies

The following optional accessory power supplies are recommended for A30 cameras:

Power Supplies	
Power Supply	Number of Cameras Supported
PG-120	2
PWR-120	2
PWR-240	4
PWR-480A	8

5.5 RS232 SERIAL INTERFACE

The signals relative to the following serial interface types are available on the M16 19-pin connector:

The main serial interface parameters (baud rate, data bits, etc.) are defined using Impact VPM software.

The following pins of the M16 19-pin connector are used for RS232 interface connection. The Impact software does not support hardware (CTS/RTS) or software (Xon/Xoff) data flow control.

Pin	Name	Function
M	TX	Transmit Data
U	RX	Receive Data
L	GND	Ground

It is always advisable to use shielded cables. The overall maximum cable length must be less than 15 m (49.2 ft.).

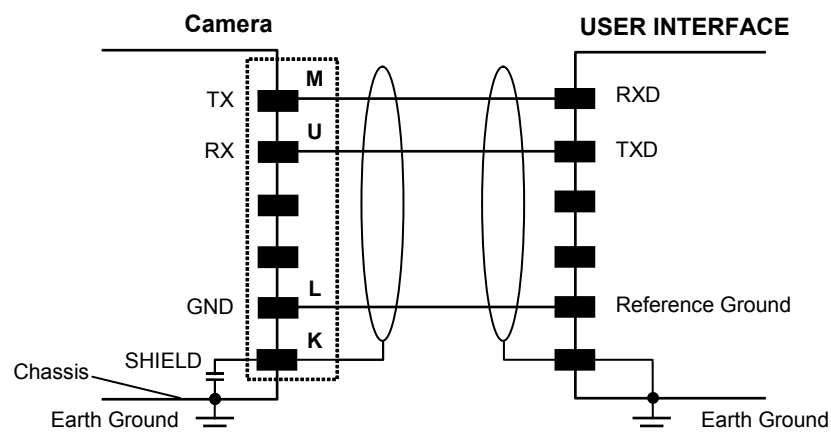

Figure 31 - RS232 Interface Connections

5.5.1 RS485 Full-Duplex Interface

The Impact software does not support RS485 protocol.

5.5.2 Auxiliary RS232 Serial Interface

The 9-pin female Auxiliary Interface connector inside the CBX is to be used by Factory and Support personnel only.



NOTE

Do not make any connections to the Aux Interface.

5.6 ETHERNET INTERFACE

The Ethernet Interface can be used for TCP/IP communication with a remote or local host computer by connecting the camera to either a LAN or directly to a host PC. There is no need to use a crossover adapter since the camera incorporates an auto-cross function.

The following is an example of a connection to a LAN using a **CAB-GE0x** straight through cable:

M12 8-Pin GigaEthernet Connector Pinout		
Pin	Name	Function
1	DB-	Channel B bi-directional data (negative pin)
2	DD+	Channel D bi-directional data (positive pin)
3	DD-	Channel D bi-directional data (negative pin)
4	DA-	Channel A bi-directional data (negative pin)
5	DC+	Channel C bi-directional data (positive pin)
6	DA+	Channel A bi-directional data (positive pin)
7	DB+	Channel B bi-directional data (positive pin)
8	DC-	Channel C bi-directional data (negative pin)

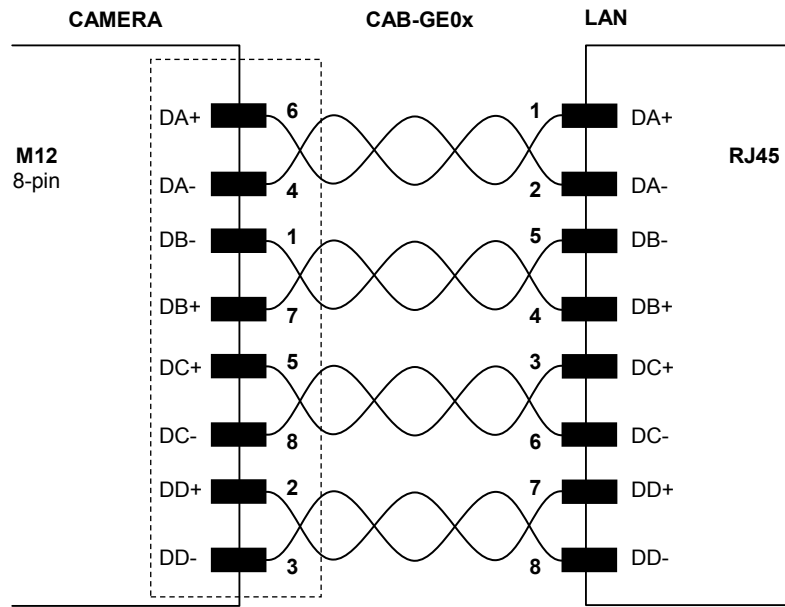

Figure 32 - CAB-GE0x GigaEthernet Cable

On the camera Ethernet interface the following communication channels are available:

- Data Socket
- Image Socket
- WebSentinel Socket
- Image FTP Client
- HTTP Server
- Ethernet IP
- Modbus TCP

5.7 INPUTS

There are two optocoupled polarity insensitive inputs available on the M16 19-pin connector of the camera: Input 1 (External Trigger) and Input 2, a generic input.

The External Trigger is the image acquisition trigger.

The main function of the general purpose Input 2 is to detect an input signal.

The electrical features of both inputs are:

INPUT	V _{AB} Min.	V _{AB} Max.	I _{IN} Max.
Open	0 V	2 V	0 mA
Closed	4.5 V	30 V	10 mA

The active states of these inputs are selected in software.

An anti-disturbance filter is implemented in software on both inputs so that the minimum pulse duration is $\cong 0.5$ milliseconds. This value can be increased through the software parameter Debounce Filter. Refer to the Camera Setup tab section in the Impact Reference Guide for further details.

These inputs are optocoupled and can be driven by both NPN and PNP type commands.



NOTE

Polarity insensitive inputs assure full functionality even if pins A and B are exchanged.

The connections are indicated in the following diagrams:

Pin	Name	Function
A	Vdc	Power Supply input voltage +
B	I1A	External Trigger + or - (polarity insensitive)
C	I1B	External Trigger + or - (polarity insensitive)
L	GND	Power Supply input voltage -

The Busy LED is on when the active state of the External Trigger corresponds to ON.

EXTERNAL TRIGGER INPUT PNP PH-1

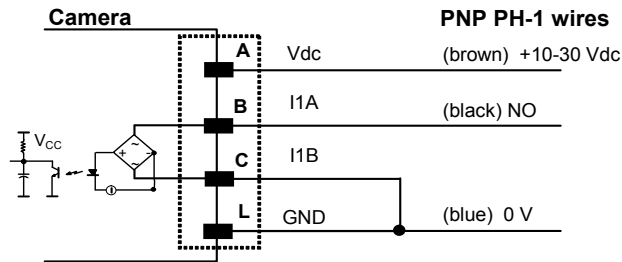

Figure 33 - External Trigger Using PNP PH-1 Photocell

EXTERNAL TRIGGER INPUT CONNECTIONS USING A30 POWER

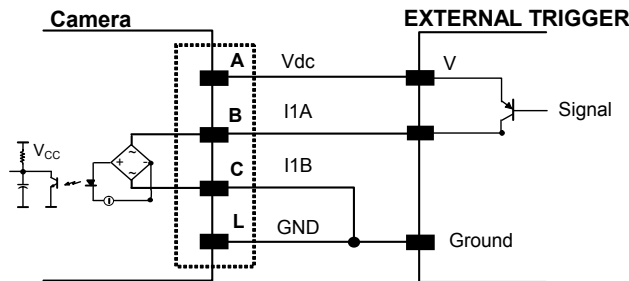

Figure 34 – External Trigger PNP Using A30 Power

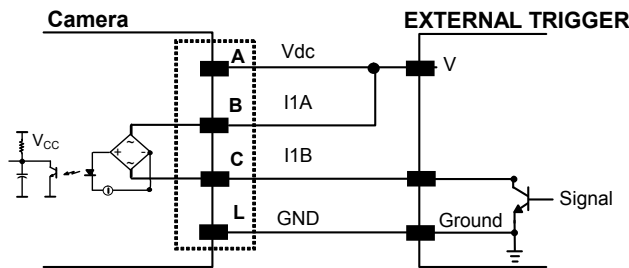

Figure 35 - External Trigger NPN Using Camera Power

EXTERNAL TRIGGER INPUT CONNECTIONS USING EXTERNAL POWER

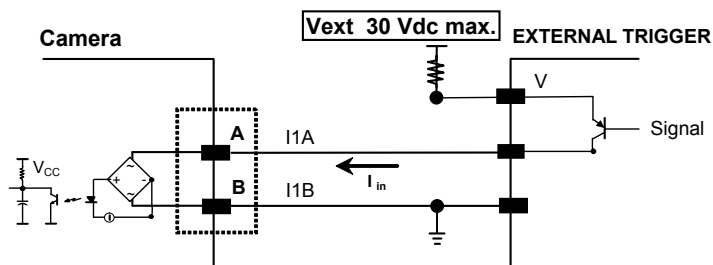

Figure 36 - External Trigger PNP Using Camera Power

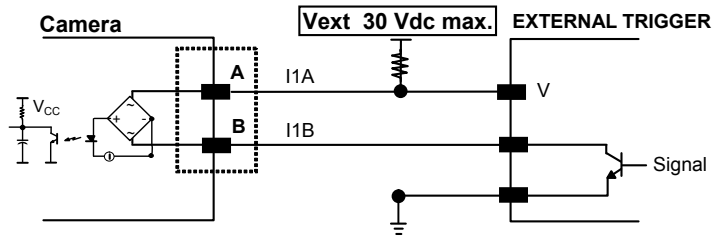

Figure 37 - External Trigger NPN Using Camera Power

INPUT 2 CONNECTIONS USING CAMERA POWER

Pin	Name	Function
A	Vdc	Power Supply input voltage +
D	I2A	Input 2 + or - (polarity insensitive)
E	I2B	Input 2 + or - (polarity insensitive)
L	GND	Power Supply input voltage -

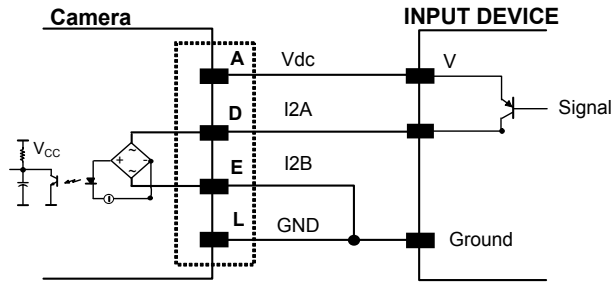

Figure 38 - Input PNP Using Camera Power

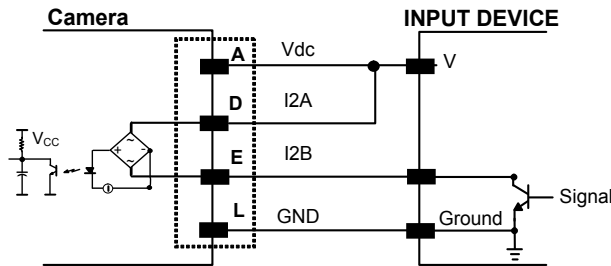

Figure 39 - Input NPN Using Camera Power

INPUT 2 CONNECTIONS USING EXTERNAL POWER

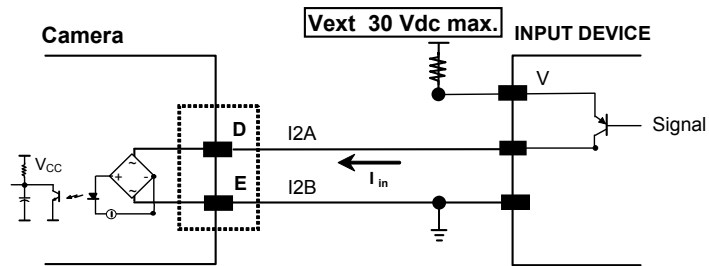

Figure 40 - Input PNP Using External Power

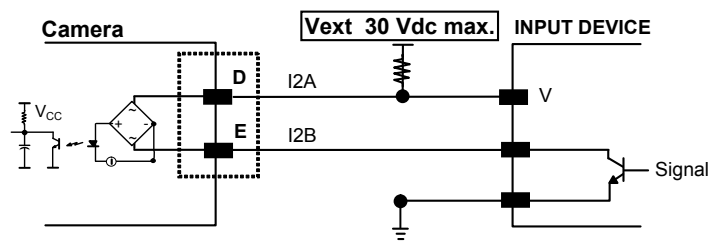

Figure 41 - Input NPN Using External Power

5.8 OUTPUTS

Three opto-coupled general purpose outputs are available on the M16 19-pin connector. The meaning of the outputs can be defined by the user. They are typically used either to signal the data collection result or to control an external lighting system.

The pinout is the following:

Pin	Name	Function
H	O1+	Configurable digital output 1 - positive pin
F	O1-	Configurable digital output 1 - negative pin
G	O2+	Configurable digital output 2 - positive pin
I	O2-	Configurable digital output 2 - negative pin
P	Strobe+/O3A	Configurable digital strobe/output 3 - positive pin*
R	Strobe-/O3B	Configurable digital strobe/output 3 - negative pin*

*The strobe signal connection is shared with Output 3. If a non-zero value is defined for the Strobe Pulse Length value (in VPM – Impact – General), the strobe is active. If the value is zero, Output 3 is active.

The electrical features of the outputs are the following:

OUTPUT	I_{Load}	V_{Out}
Open	0 mA	30 Vdc Max
Closed	10 mA	1.8 Vdc Max

$$P_D = V_{Out} \times I_{oLoad} = 170 \text{ mW Max.}$$

The output signals are fully programmable. Refer to the Discrete Output tool section in the Impact Reference Guide for further details.

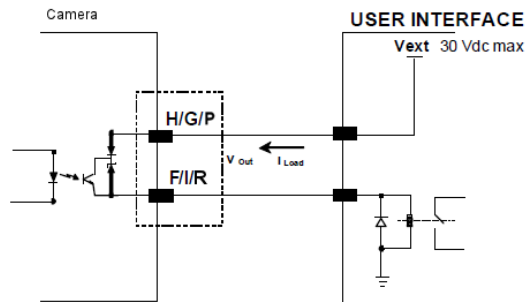

Figure 42 - Open Emitter Output Connection

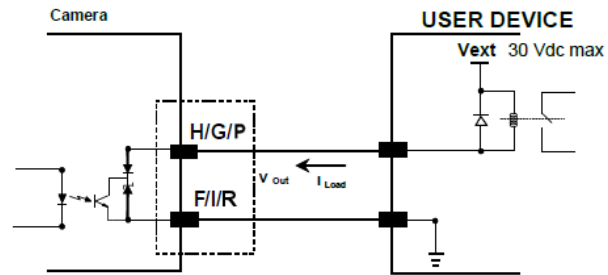

Figure 43 - Open Collector Output Connection

How To Build A Simple Interface Test Cable:

The following wiring diagram shows a simple test cable including power and external (push-button) trigger and Input 2 connections.

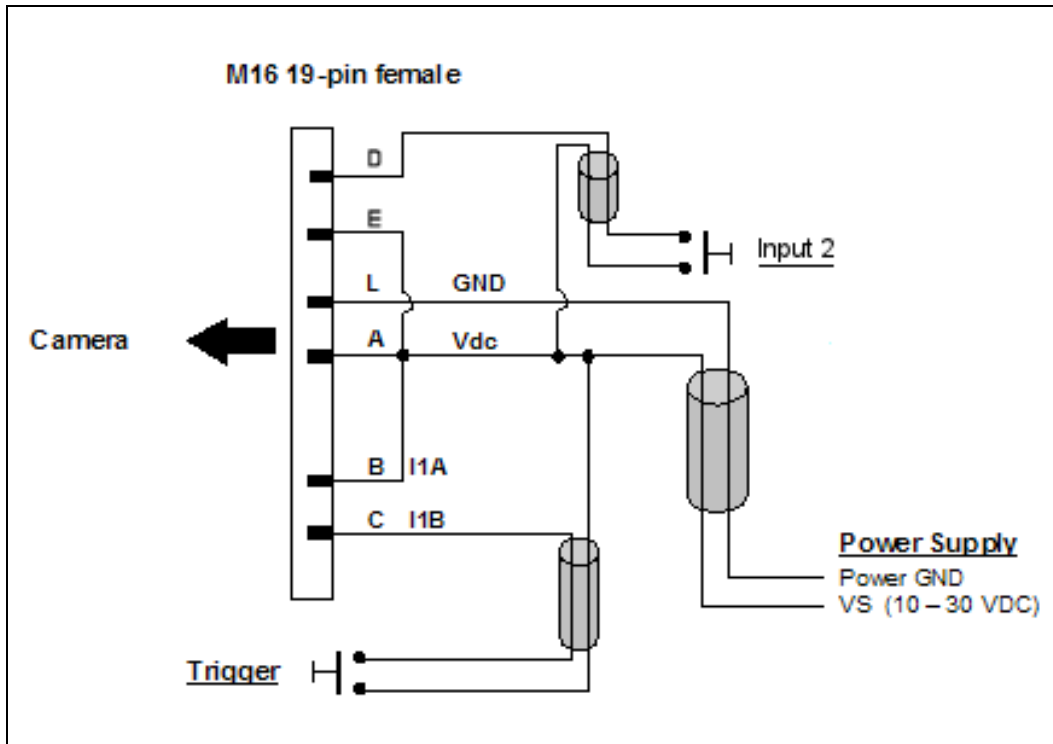

Figure 44- Test Cable for the Camera

6 TYPICAL LAYOUTS

The following typical layouts refers to system hardware configurations. However, these layouts also require the correct setup of the software configuration parameters.

6.1 EMBEDDED (ON-BOARD) GIGAETHERNET

A point-to-point configuration can be made to the on-board Ethernet connection. In order to be recognized by VPM, it is necessary to align the camera's Ethernet parameters using VPM. For further details, refer to Configuring the Impact Device or Camera in the Impact Reference Guide.

In a Point-to-Point layout the camera is connected to a local host by using a **CAB-GE0x** cable. There is no need to use a crossover adapter since the camera incorporates an autocross function.



Figure 45 - Standalone Layout to Ethernet Host (Point-to-Point)

6.2 ETHERNET NETWORKS

6.2.1 External Trigger Ethernet Host

When using a Local Area Network (LAN), one or more cameras can be connected to the network by using **CAB-GE0x** cables. In the example below an External Trigger is used which is connected through a CBX connection box.

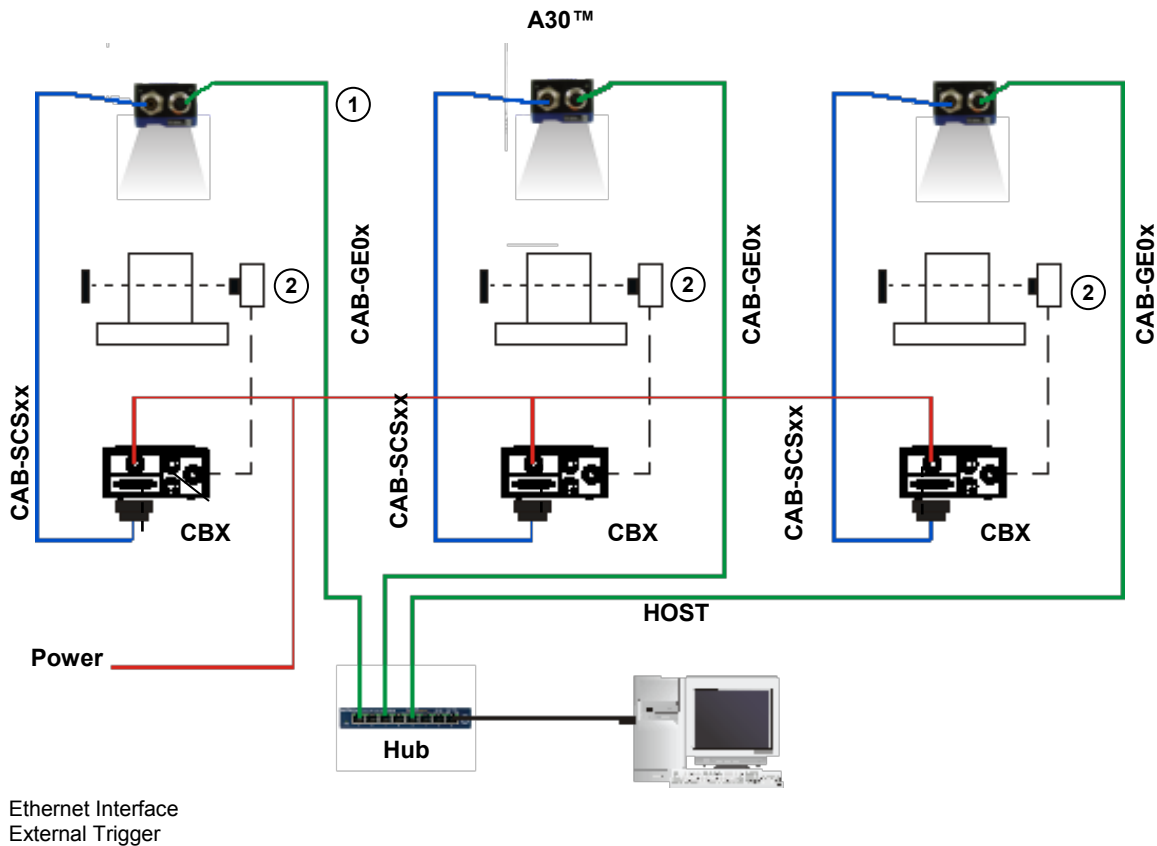



Figure 46 - Ethernet Network Layout

NOTE  The camera does not support sourcing power towards the CBX in order to power I/O devices (including the External Trigger). These devices must be powered from the CBX or from an external source.

6.2.2 Software Trigger Ethernet Host

The LAN connections are simplified when a software Trigger is supplied by the host. In this case, the CBX connection box is not necessary.

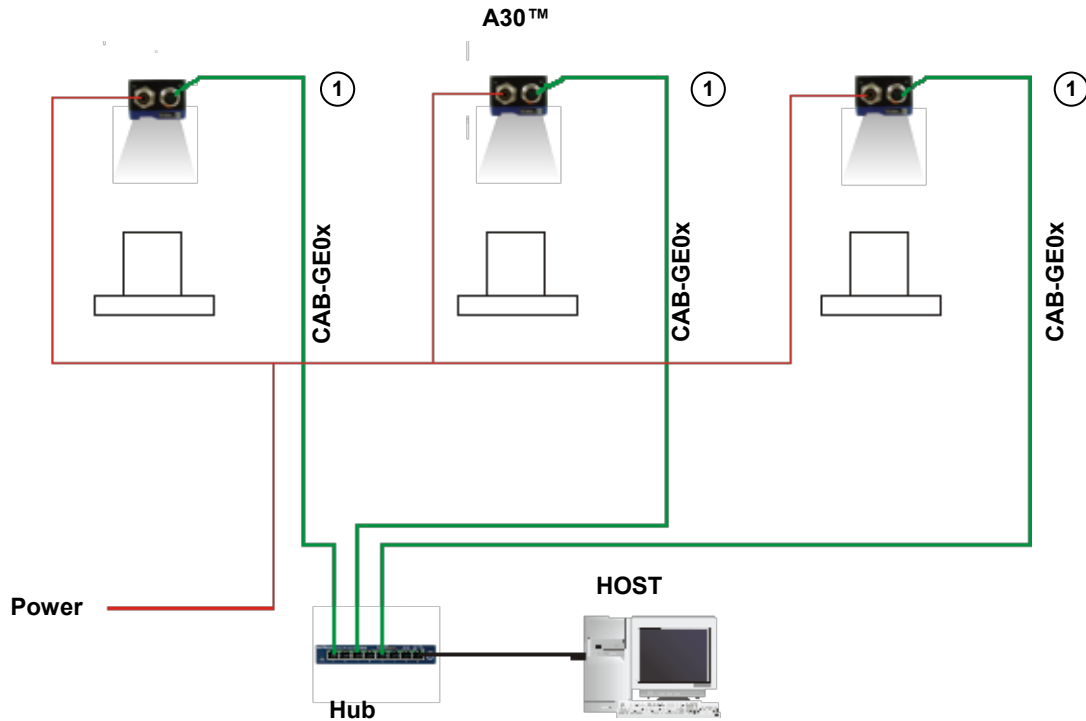

Figure 47 - Ethernet Network Layout

① Ethernet Interface

7 IMAGE CAPTURE FEATURES

7.1 MAXIMUM LINE SPEED AND EXPOSURE TIME CALCULATIONS

The **Exposure Time** (or **Shutter**) parameter defines the time during which the image will be exposed to the image sensor to be acquired. This parameter depends heavily on the environmental conditions (external lighting system, image contrast etc.).

In general, a longer time corresponds to a lighter image but is susceptible to blurring due to the part movement; a shorter exposure time corresponds to a darker image.

Assuming:

- **X**: Part Resolution (mm)
- **T_{exp}**: Exposure Time (s)
- **LS**: Line Speed (mm/s)

The essential condition to avoid blurring effects between two adjacent elements in a dynamic inspection application is:

$$LS * T_{exp} \leq X$$

The maximum (theoretical) line speed **LS** can be calculated as follows:

$$X / T_{exp (max)} = LS_{(max)}$$

Example:

Using:

Lighting Mode = Very High Power Strobe

Exposure Time (x10 μs) = 10 (100 μs)

Part Resolution (X) = 0.254 mm (10 mils)

has a maximum line speed of:

$$0.254 \text{ (mm)} / 0.0001 \text{ (s)} = 2540 \text{ mm/s}$$

Likewise, **T_{exp (max)}** is the maximum **Exposure Time** value that can be used without blurring for the given application line speed and code resolution. Therefore:

$$X / LS_{(max)} = T_{exp (max)}$$

$T_{exp (max)}$ and $LS_{(max)}$ are represented in the graph below as the curved line for **X** (image resolution). Values above the curve result in blurring. In practice, the application values are somewhere below the theoretical line due to environmental and other conditions.

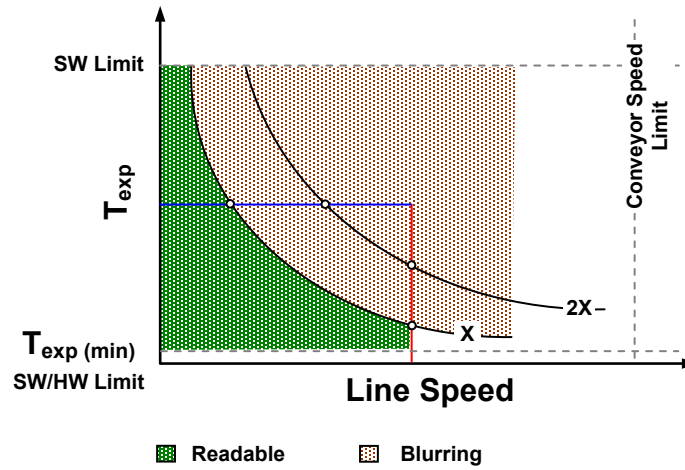

For example, the maximum target speed in the application is also affected by these conditions:

- **Part/Background Contrast:** maximum speed decreases when decreasing image contrast (poor quality images, reflective transparent coverings, different supports and printing techniques).
- **Part Resolution:** maximum speed increases when decreasing part resolution, (i.e. **2X**). There is a decrement of overlapping effects between two adjacent elements.
- **Tilt Angle:** maximum speed decreases when increasing Tilt angle (from 0 to 45 degrees).

$T_{exp (min)}$ is the minimum **Exposure Time** value obtainable for the specific application. It can be evaluated in static inspection conditions and depends on the camera hardware selected for the application (lighting system, optical lens, diaphragm aperture, distance) and on any external lighting system. It may also depend on part clarity and camera position.

8 SOFTWARE CONFIGURATION

Software configuration of your A30 camera can be accomplished by the procedures described in the Impact Reference Guide. VPM is used to configure the camera for specific applications, and provides the tools to create vision programs.

8.1 VPM™ SYSTEM REQUIREMENTS

To install and run Vision Program Manager™ you should have a Laptop or PC that meets or exceeds the requirements defined in the system requirements section of the Impact Reference Guide.

8.2 INSTALLING IMPACT SOFTWARE

To install Impact Software, proceed as follows:

1. Turn on the Laptop or PC that will be used for configuration (connected to the Ethernet port of the A30 camera).
2. You may need to turn off automatic virus checking during the install if it causes installation problems.
3. You must log in to an operating system account that has administrative privileges in order to install or run Impact software on a Windows operating system.
4. Double-click on the installation file.
5. The installation program should start. Select the language you want the install to use, then click OK.
6. Follow the on-screen instructions. You will have the option to install Impact software to the client, camera, or both.
Note: If security is enabled on the camera, you cannot install new software on it. You must exit the install program, disable security on the camera, then restart the install.
7. When the installation has completed, you can start VPM.

8.3 STARTUP

After completing the mechanical and electrical connections to the A30 camera, you can begin software configuration as follows:

1. Power on the camera. Wait for the camera startup. The system bootstrap requires a few seconds to complete.
2. Start VPM. It will automatically search for any cameras on the network. Select the desired camera from the list, then click Connect to Device. The PC will automatically connect to the camera.

Upon connection, VPM is in Edit mode with all the tools necessary to create vision programs. Refer to the Impact Reference Guide for more details.

8.3.1 Calibration

VPM provides calibration software to insure that the measurements indicated in VPM tools accurately relate to the inspected object's measurements. You may calibrate a camera using a calibrated target, a part with known dimensions, or you can enter the camera's units-per-pixel factor manually.

Refer to the Calibration Panel section of the Impact Reference Guide for details.

Under-exposure:

To correct this result it is recommended to change the parameters in the following order:

1. increase the **Exposure Time**
2. increase the **Gain**



NOTE

*In general, a longer exposure time corresponds to a lighter image but is susceptible to blurring due to code movement. Exposure time is also limited by the lighting. **Longer exposure times can be set if the power stroke level is lowered.***

High gain settings may produce a grainy image that may affect the inspection process.

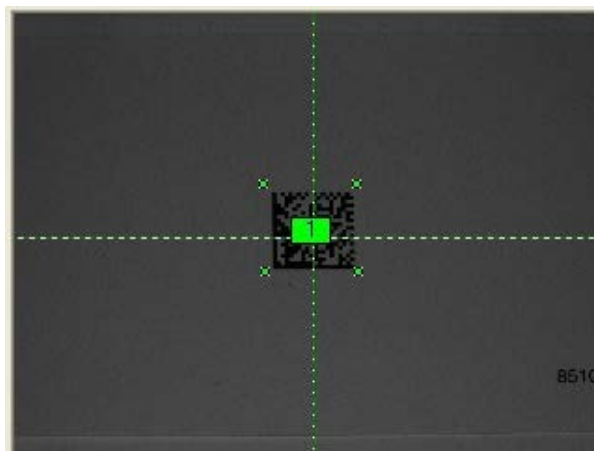

Figure 48 - Example Under Exposure: Too Dark

Over-exposure:

To correct this result, change the parameters in the following order:

1. decrease the **Gain**
2. decrease the **Exposure Time**

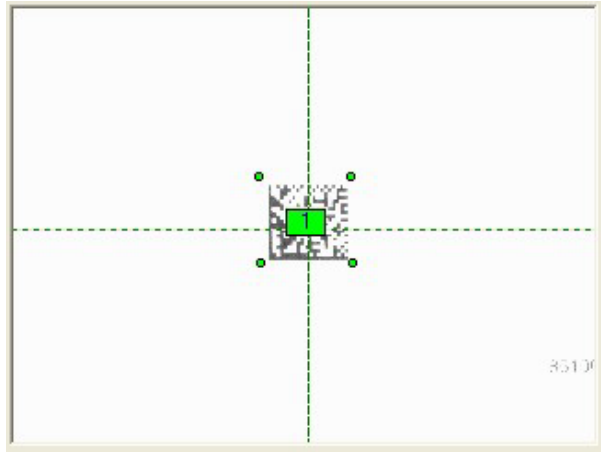

Figure 49 - Example Over Exposure: Too Light

8.3.2 Partial Scan

In order to satisfy very high throughput applications, higher frame rates can be achieved using the powerful **Partial Scan** parameters in the Camera setup menu.

Partial Scan allows defining a region or window within the camera Field of View. The Top, Bottom, Left and Right parameters allow you to precisely define the image window to be processed.

In the camera the frame rate is dependent on the number of lines (or rows) in the defined window.

The smaller the window, the lower the frame period, and consequently the higher the frame rate. In general the Image Processing time can be reduced by reducing the window dimensions.

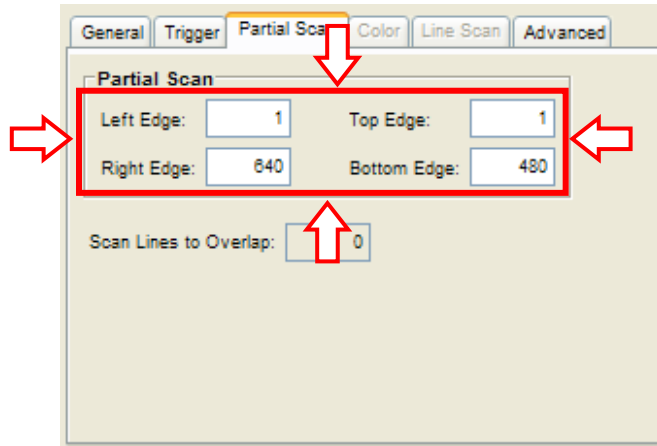

9 MAINTENANCE

9.1 CLEANING

Use soft material and alcohol to clean the lens and cover and avoid any abrasive substances.

Clean the lens and lens cover periodically for continued correct operation of the camera.

Repeat the cleaning more frequently in particularly dirty environments.

Dust, dirt, etc. on the lens or cover may alter the image clarity.

10 TROUBLESHOOTING

10.1 GENERAL GUIDELINES

- When wiring the device, pay careful attention to the signal name on the CBX500 spring clamp connectors (chapter. 1). If you are connecting directly to the A30 M16 19-pin connector, pay attention to the pin number of the signals (chapter. 1).
- If you need information about a certain camera parameter, you can refer to the Impact Reference Guide.
- If you're unable to fix the problem and you're going to contact your local DLA office, DLA Partner or ARC, we suggest providing (if possible) the Software version, Parameter Configuration file, Serial Number and Order Number of your camera. You can get some of this information in VPM while it is connected to the camera. The software version is shown in the About dialog and the Serial Number can be obtained from the Device Connection dialog.

TROUBLESHOOTING GUIDE	
Problem	Suggestion
<p>Power ON: the "POWER" LED is not lit.</p>	<ul style="list-style-type: none"> • Is power connected? • If using a power adapter (like PG-120), is it connected to wall outlet? • If using rail power, does rail have power? • If using CBX, does it have power (check switch and LED)? • Check if you are using the M16 19-pin connector or the CBX spring clamp connectors. • Measure Voltage either at pin A and pin L (for 19-pin connector) or at spring clamp Vdc and GND (for CBX).
<p>Using the Input 1 (External Trigger) or Input 2: the "BUSY" LED is not blinking while the External Trigger is switching.</p>	<ul style="list-style-type: none"> • Check if you are using the 19-pin connector or the CBX spring clamp connectors. • Is the sensor connected to the Input 1 or Input 2? • Is power supplied to the photo sensor? • For NPN configuration, is power supplied to one of the two I1 or I2 signals (A or B)? • For PNP configuration, is one of the two I1 or I2 signals grounded (A or B)? • Is the sensor/reflector system aligned (if present)? • In VPM, check the EXTERNAL TRIGGER or INPUT 2 Debounce Filter parameter setting. • In VPM, check the Camera Trigger settings.

TROUBLESHOOTING GUIDE	
Problem	Suggestion
Using the Input 1 (External Trigger) the "TRIGGER" LED is correctly blinking but no image is displayed in VPM.	<ul style="list-style-type: none"> • Is the Camera online?
Image not clear:	<ul style="list-style-type: none"> • verify the camera focus
Image focused but tool measurements are inaccurate	<ul style="list-style-type: none"> • verify the Image calibration.
Communication: camera is not transmitting anything to the host.	<ul style="list-style-type: none"> • Is the Ethernet cable wiring correct? • Is the Ethernet cable connected? • Are the camera and host PC IP addresses set correctly?
Communication: data transferred to the host are incorrect, corrupted or incomplete.	<ul style="list-style-type: none"> • Is the Ethernet cable intermittent?
How do I obtain my camera Serial Number?	<ul style="list-style-type: none"> • The camera Serial Number consists of the character "C" followed by a series of numbers. It is printed on a label that is affixed to the side of the case. • The Serial Number can also be obtained in the Device Connect dialog in VPM.

11 TECHNICAL FEATURES

ELECTRICAL FEATURES	
Power	
Supply Voltage	10-30 Vdc ± 20%
Consumption (max)	0.8 to 0.27 A, 8 W max.; 0.5 to 0.17 A, 5 W typical
Communication Interfaces	
RS232	2400 to 115200 bit/s
Ethernet	10/100/1000 Mbit/s, Gigabit Ethernet
Inputs	
Input 1(External Trigger) and Input 2	Opto-coupled and polarity insensitive
Max. Voltage	30 Vdc
Max. Input Current	10 mA
Outputs	
Output 1, Output 2 and Strobe/Output 3	Opto-coupled
V _{Out} (I _{Load} = 0 mA) Max.	30 Vdc
V _{Out} (I _{Load} = 10 mA) Max.	1.8 Vdc
P _D = V _{Out} × I _{Load} Max.	170 mW
OPTICAL FEATURES	
Image Sensor	CCD
Image Format	640 x 480
Frame Rate	60 frames/sec
ENVIRONMENTAL FEATURES	
Operating Temperature ¹	0 to 45 °C (32 to 113 °F)
Storage Temperature	-20 to 70 °C (-4 to 158 °F)
Max. Humidity	90% non-condensing
Vibration Resistance EN 60068-2-6	14 mm @ 2 to 10 Hz; 1.5 mm @ 13 to 55 Hz; 2 g @ 70 to 200 Hz; 2 hours on each axis
Shock Resistance EN 60068-2-27	30g; 11 ms 3 shocks on each axis
Protection Class ² EN 60529	IP67
PHYSICAL FEATURES	
Dimensions	125 x 65 x 86 mm (4.92 x 2.56 x 3.39 in.) with lens cover
Weight (with lens)	482 g. (17 oz.)
Material	Aluminum
Parameter Storage	Permanent memory (Flash)
USER INTERFACE	
LED Indicators	Power, Busy/Trigger, Out 1; Out 2; Out 3, Online
Keypad Button	Reset

¹ High ambient temperature applications should use metal mounting bracket for heat dissipation.

² Requires correct connection to IP67 cables with seals and Lens Cover mounting.

GLOSSARY

AIM

(Association for Automatic Identification and Mobility): AIM Global is the international trade association representing automatic identification and mobility technology solution providers.

AIM DPM Quality Guideline

Standard applicable to the symbol quality assessment of direct part marking (DPM) performed in using two-dimensional bar code symbols. It defines modifications to the measurement and grading of several symbol quality parameters.

AS9132

Standard defining uniform quality and technical requirements for direct part marking (DPM) using Data Matrix symbologies.

Barcodes (1D Codes)

A pattern of variable-width bars and spaces which represents numeric or alphanumeric data in machine-readable form. The general format of a barcode symbol consists of a leading margin, start character, data or message character, check character (if any), stop character, and trailing margin. Within this framework, each recognizable symbology uses its own unique format.

BIOS

Basic Input Output System. A collection of ROM-based code with a standard API used to interface with standard PC hardware.

Bit

Binary digit. One bit is the basic unit of binary information. Generally, eight consecutive bits compose one byte of data. The pattern of 0 and 1 values within the byte determines its meaning.

Bits per Second (bps)

Number of bits transmitted or received per second.

Byte

On an addressable boundary, eight adjacent binary digits (0 and 1) combined in a pattern to represent a specific character or numeric value. Bits are numbered from the right, 0 through 7, with bit 0 the low-order bit. One byte in memory can be used to store one ASCII character.

Composite Symbologies

Consist of a linear component, which encodes the item's primary data, and an adjacent 2D composite component, which encodes supplementary data to the linear component.

Dark Field Illumination

Lighting of surfaces at low angles used to avoid direct reflection of the light in the camera's lens.

Decode

To recognize a barcode symbology (e.g., Codabar, Code 128, Code 3 of 9, UPC/EAN, etc.) and analyze the content of the barcode scanned.

Depth of Field

The difference between the minimum and the maximum distance of the object in the field of view that appears to be in focus.

Diffused Illumination

Distributed soft lighting from a wide variety of angles used to eliminate shadows and direct reflection effects from highly reflective surfaces.

Direct Part Mark (DPM)

A symbol marked on an object using specific techniques like dot peening, laser etching, chemical etching, etc.

EEPROM

Electrically Erasable Programmable Read-Only Memory. An on-board non-volatile memory chip.

Element

The basic unit of data encoding in a 1D or 2D symbol. A single bar, space, cell, dot.

Exposure Time

For digital cameras based on image sensors equipped with an electronic shutter, it defines the time during which the image will be exposed to the sensor to be acquired.

Flash

Non-volatile memory for storing application and configuration files.

Host

A computer that serves other terminals in a network, providing services such as network control, database access, special programs, supervisory programs, or programming languages.

Image Processing

Any form of information processing for which the input is an image and the output is for instance a set of features of the image.

Image Resolution

The number of rows and columns of pixels in an image. The total number of pixels of an image sensor.

Image Sensor

Device converting a visual image to an electric signal. It is usually an array of CCD (Charge Coupled Devices) or CMOS (Complementary Metal Oxide Semiconductor) pixel sensors.

IEC

(International Electrotechnical Commission): Global organization that publishes international standards for electrical, electronic, and other technologies.

IP Address

The terminal's network address. Networks use IP addresses to determine where to send data that is being transmitted over a network. An IP address is a 32-bit number referred to as a series of 8-bit numbers in decimal dot notation (e.g., 130.24.34.03). The highest 8-bit number you can use is 254.

ISO

(International Organization for Standardization): A network of the national standards institutes of several countries producing world-wide industrial and commercial standards.

LED (Light Emitting Diode)

A low power electronic light source commonly used as an indicator light. It uses less power than an incandescent light bulb but more than a Liquid Crystal Display (LCD).

LED Illuminator

LED technology used as an extended lighting source in which extra optics added to the chip allow it to emit a complex radiated light pattern.

Matrix Symbologies (2D Codes)

An arrangement of regular polygon shaped cells where the center-to-center distance of adjacent elements is uniform. Matrix symbols may include recognition patterns which do not follow the same rules as the other elements within the symbol.

Multidrop

A communication protocol for connecting two or more cameras in a network with a concentrator (or controller) and characterized by the use of individual device addresses.

Multi-row (or Stacked) Symbologies

Symbologies where a long symbol is broken into sections and stacked one upon another similar to sentences in a paragraph.

RAM

Random Access Memory. Data in RAM can be accessed in random order, and quickly written and read.

Transmission Control Protocol/Internet Protocol (TCP/IP)

A suite of standard network protocols that were originally used in UNIX environments but are now used in many others. The TCP governs sequenced data; the IP governs packet forwarding. TCP/IP is the primary protocol that defines the Internet.

INDEX

A

Accessories, 7
Auxiliary RS232 Serial Interface, 15
Auxiliary Serial Interface, 29

C

Calibration, 44
Camera
 button, 6
 reset, 6
Camera Electrical Connections, 24
CBX Electrical Connections, 13
CBX500 Connectors, 3
Compliance, iii
Connect the System, 2
Connectors
 GigaEthernet Connector, 27
 Power, Serial, I/O, 24, 25

E

Ethernet Interface, 29, 38
Ethernet Networks
 software trigger, 40
Ethernet Networks
 external trigger, 39
Event
 Camera button, 6
Exposure Time, 41
External Illuminators, 23

G

General View, vii
Glossary, 51

H

Handling, iv

I

Image Capture Features, 41
Indicators, 6
Inputs, 16, 31

Installing Impact Software, 43

L

Layouts
 Ethernet Networks, 39, 40
 typical, 38
Line Speed, 41

M

Maintenance, 47
Mechanical Dimensions, 9
Mounting the Camera, 11

O

Outputs, 21, 35

P

Package Contents, 8
Partial Scan, 45
Power Supply, iv, 14, 27
Product Description, 5

R

Rapid Configuration, 1
References, iii
Reset button, 6
RS232 Serial Interface
 signals, 28
 terminals, 15

S

Software Configuration, 43
Startup, 44
System Requirements, 43

T

Technical Features, 50
Test cable
 diagram, 37
Trigger
 Camera button event, 6
Troubleshooting, 48

www.datalogic.com